

N69-31783

NASA CR-96008

AIRCRAFT STABILITY AND CONTROL DATA

By Gary L. Teper

April 1969

Distribution of this report is provided in the interest of information exchange and should not be construed as endorsement by NASA of the material presented. Responsibility for the contents resides in the author or organization that prepared it.

Prepared under Contract No. NAS 2-4478 by

Systems Technology, Inc.
Hawthorne, California

for

Ames Research Center
NATIONAL AERONAUTICS AND SPACE ADMINISTRATION

REPRODUCED BY
NATIONAL TECHNICAL
INFORMATION SERVICE
U.S. DEPARTMENT OF COMMERCE
SPRINGFIELD, VA. 22161

FOREWORD

This report was prepared under Contract NAS2-4478 between Systems Technology, Inc., Hawthorne, California and the National Aeronautics and Space Administration. The NASA project monitor was L. W. Taylor. The STI project engineer was Gary L. Teper.

The author gratefully acknowledges the aid of the STI staff in collecting, interpreting, and organizing the data. The author also wishes to acknowledge the fine work of the STI publications department in the preparation of this report.

ABSTRACT

Data of interest to handling qualities investigators is presented for various current aircraft. Included are those required to obtain transfer functions for the aircraft's response to control inputs. Where possible, an analytical description of the aircraft's stability augmentor is given, and also the complete flight envelope of each aircraft is covered for its most common configuration and loading. Computed transfer functions for various flight conditions are included.

CONTENTS

	<u>Page</u>
I. INTRODUCTION	1
II. A-7A	3
III. A-4D	27
IV. F-106B.	49
V. T-38	57
VI. F-5A	65
VII. F-104	73
VIII. F-105B.	81
IX. B-58	91
X. NAVION.	99
XI. DC-8	105
APPENDIX A. AXIS SYSTEMS, SYMBOLS, AND DERIVATIVE DEFINITIONS .	A-1
APPENDIX B. TRANSFORMATION OF NON-DIMENSIONAL STABILITY AXIS DERIVATIVES TO BODY AXIS	B-1
APPENDIX C. EQUATIONS OF MOTION, TRANSFER FUNCTIONS, AND COUPLING NUMERATORS	C-1

SECTION I

INTRODUCTION

The purpose of this document is to provide handling qualities investigators with readily usable data on various current aircraft. Included are those data required to obtain transfer functions relating the aircraft's response to control inputs. An analytical description of the aircraft's stability augmentor is also given.

For those aircraft for which complete information was available, the following summarizes the contents and presentation:

1. A general description is given, including:
 - a. Three-view drawing and reference geometry.
 - b. Flight envelope.
 - c. Nominal configuration (weight, inertias, and c.g. location).
 - d. References.
 - e. Basic data sources.
2. A block diagram of the augmentor showing feedbacks, gains, and scheduling.
3. Trim angle-of-attack and elevator versus Mach number and altitude.
4. Longitudinal and lateral nondimensional stability derivatives* versus Mach number and altitude for the trimmed nominal configuration.
5. Geometrical parameters, longitudinal and lateral dimensional derivatives, and longitudinal and lateral transfer functions for the nominal configuration at various flight conditions. These data are usually given for body-fixed centerline axes (body axes).

For the remaining aircraft, some portion of the above is presented as dictated by the limits of the available data.

*These are given for the axis system of the data source.

The intention has been to make this report completely self-consistent insofar as symbols, nomenclature, definitions, etc. The system used is described in three appendices. Appendix A covers axis systems, symbols and notation, and definitions of nondimensional and dimensional stability derivatives. Appendix B gives the axis system transformations for the derivatives. Appendix C includes the aircraft equations of motion and transfer functions used herein.

While complete coverage of each aircraft including only the "latest" and "best" data would be desirable, the major criterion used was that the data be immediately accessible to the author. This is why only isolated flight conditions are given for some aircraft, and also why, as those people more intimately familiar with each particular aircraft will recognize, the data presented may represent an early estimate in the design process and perhaps the "nominal configuration" is one which never left the drawing board. The data have been reviewed and, although not all those presented indicate unquestionable trends, those data known to be based on only early "guesstimates" or showing unreasonable trends have been deleted. As to how well the data can be expected to match the flying aircraft, it is assumed that those for whom this document is intended know well the difficulties of obtaining derivatives from flight test data. Every attempt has been made to insure reliable translation, interpretation, and transcription of the data from their source documents.

The manufacturers of the aircraft described herein can not be held accountable for the information presented, nor would they be bound to concur in any conclusions with respect to their aircraft which might be derived from its use.

SECTION II

A-7A

Figure II-1

A-7A

TR-176-1

NOMINAL CRUISE CONFIGURATION

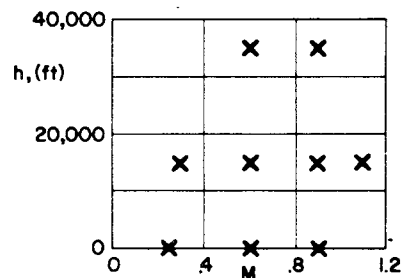
Clean Airplane
 60% Fuel
 W = 21,889 lbs
 CG at 30% MGC
 $I_x = 13,635$ Slug ft²
 $I_y = 58,966$ Slug ft²
 $I_z = 67,560$ Slug ft²
 $I_{xz} = 2,933$ Slug ft²

} Body
 Ref.
 Axes

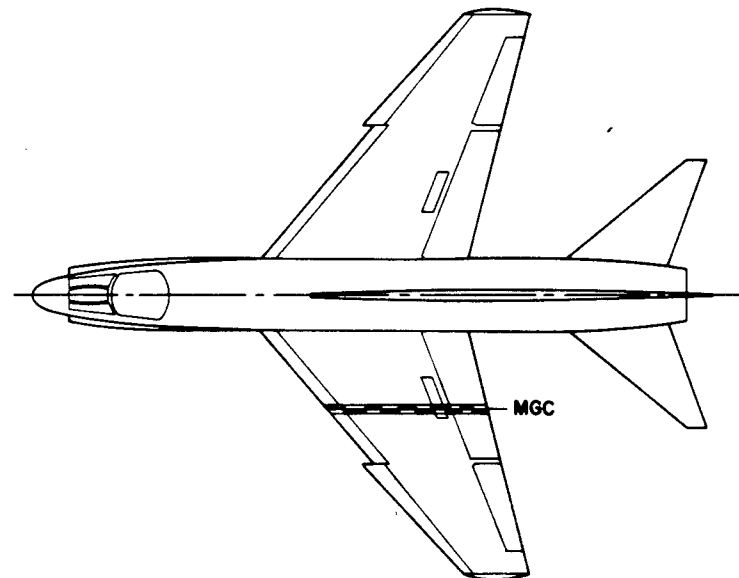
REFERENCE GEOMETRY

S = 375 ft²
 c = 10.8 ft
 b = 38.7 ft

FLIGHT ENVELOPE

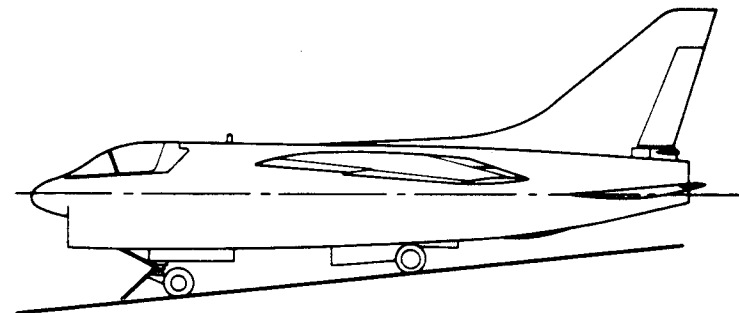
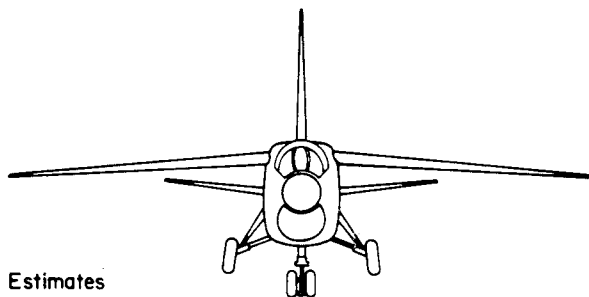


X Transfer functions given
 for these flight conditions



REFERENCES

- 1) LTV Vought Aeronautics Div. Rept. No. 2-53310/5R-1981, "A-7A Aerodynamics Data Report", 21 May 1965 (U)
- 2) LTV Vought Aeronautics Div. Rept. No. 2-53310/5R-5121, Rev. I, "A-7A Estimated Flying Qualities", 20 August 1965 (C)
- 3) LTV Vought Aeronautics Div., "Updated A-7A Aircraft Lateral-Directional Cruise Device Configuration Data", 25 August 1967

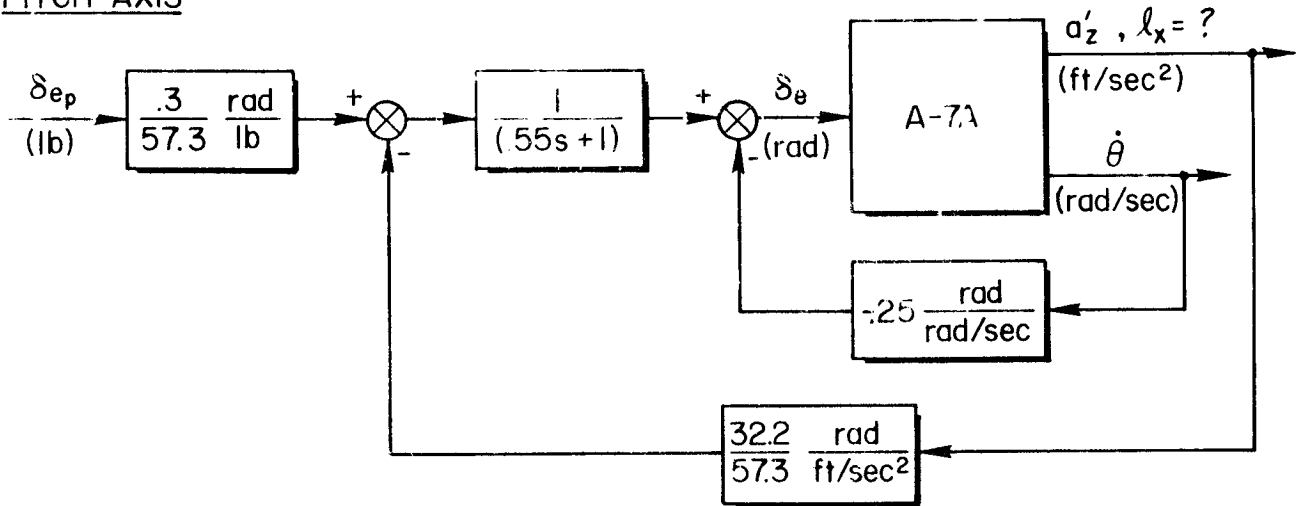


BASIC DATA SOURCES

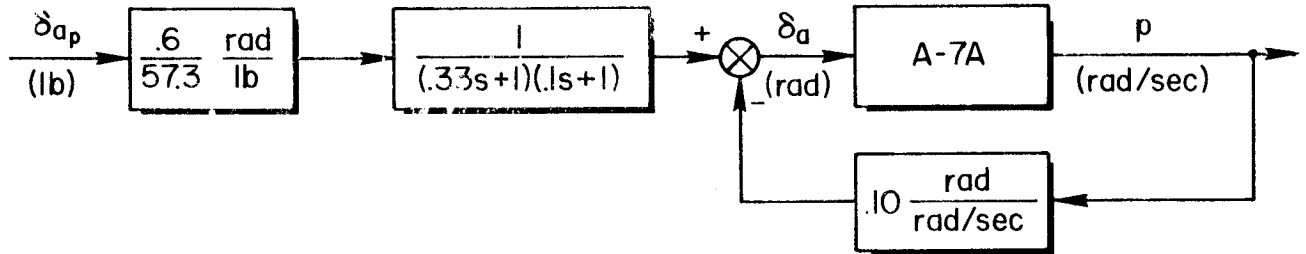
Wind Tunnel Test and Estimates
 Some Lateral-Directional Derivatives
 Adjusted After Flight Test

4

PITCH AXIS



ROLL AXIS



YAW AXIS

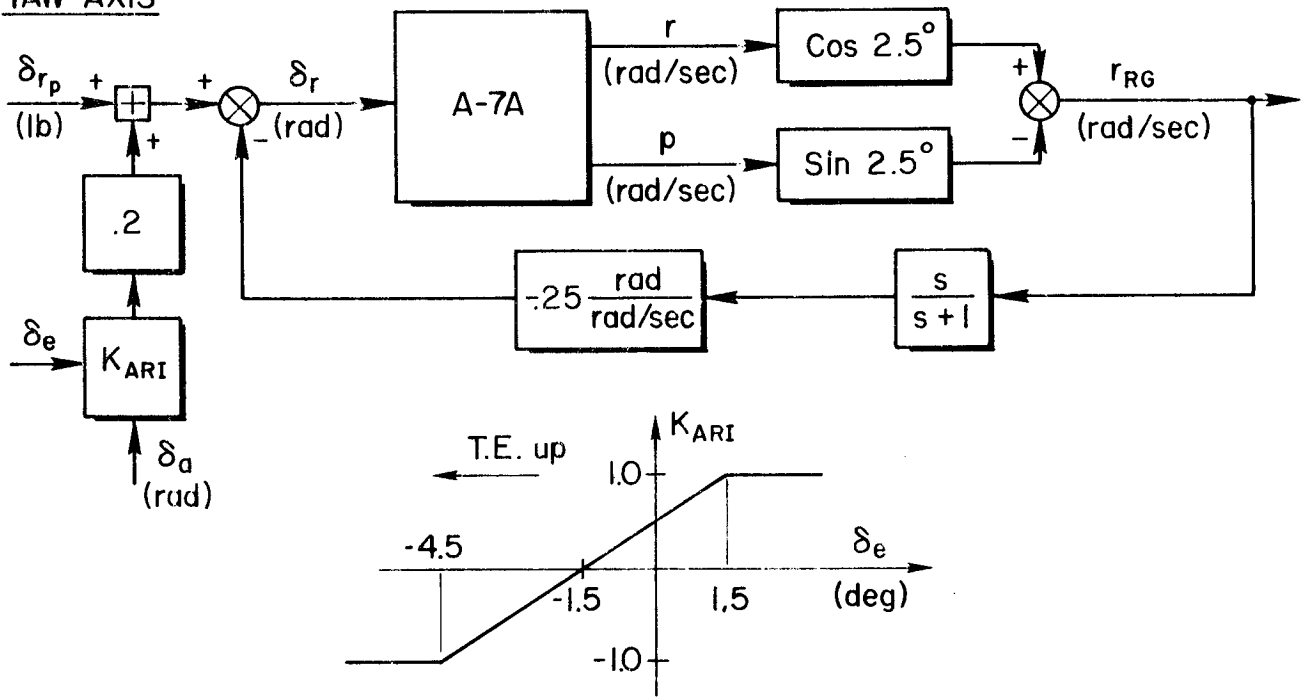
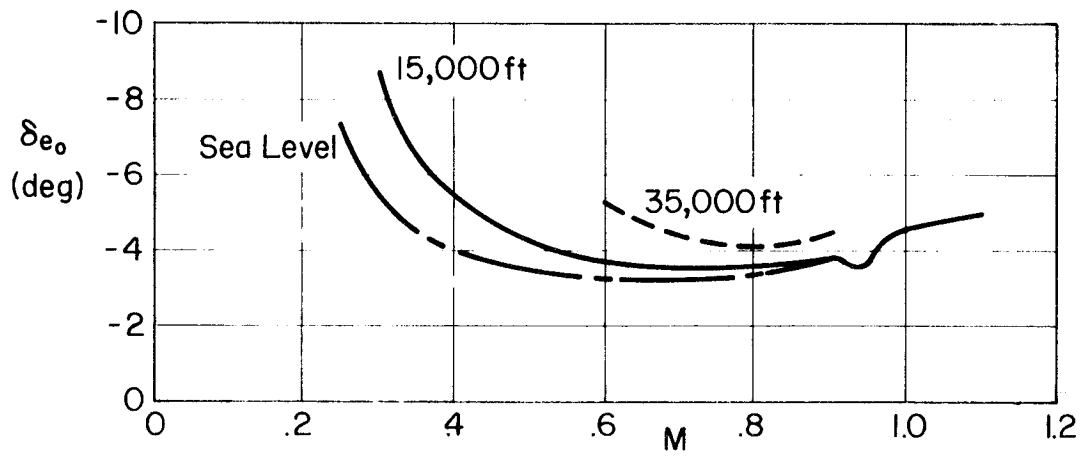
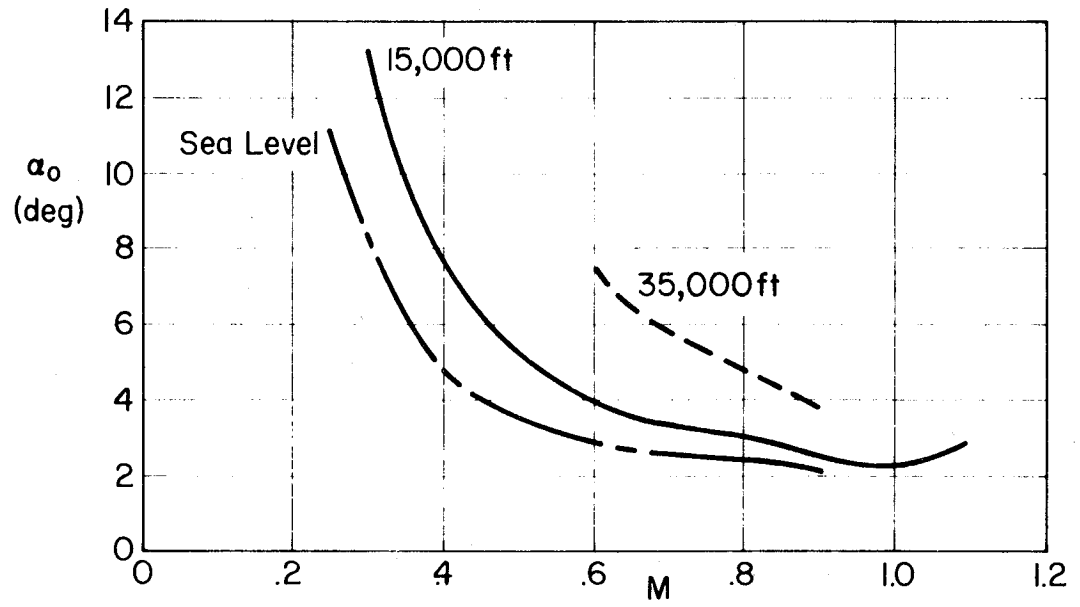
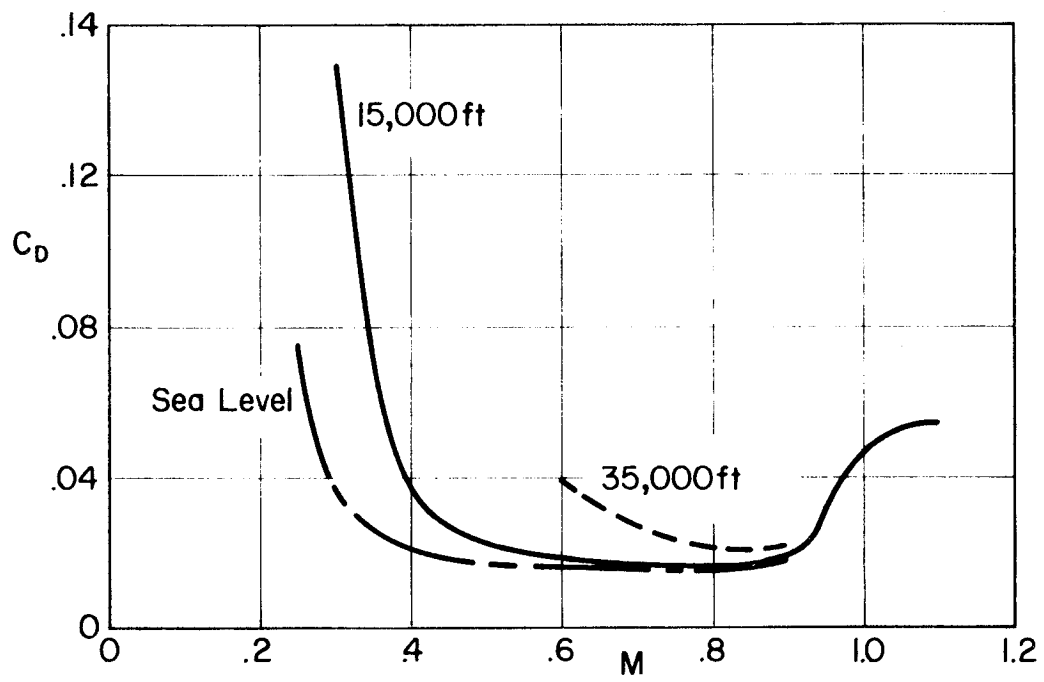
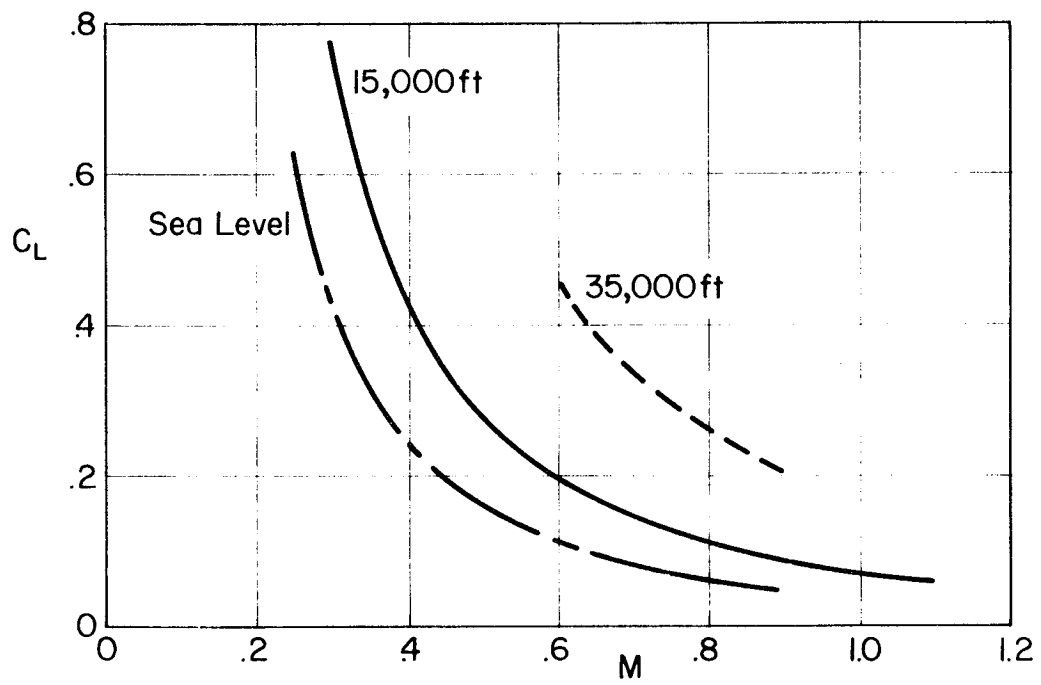
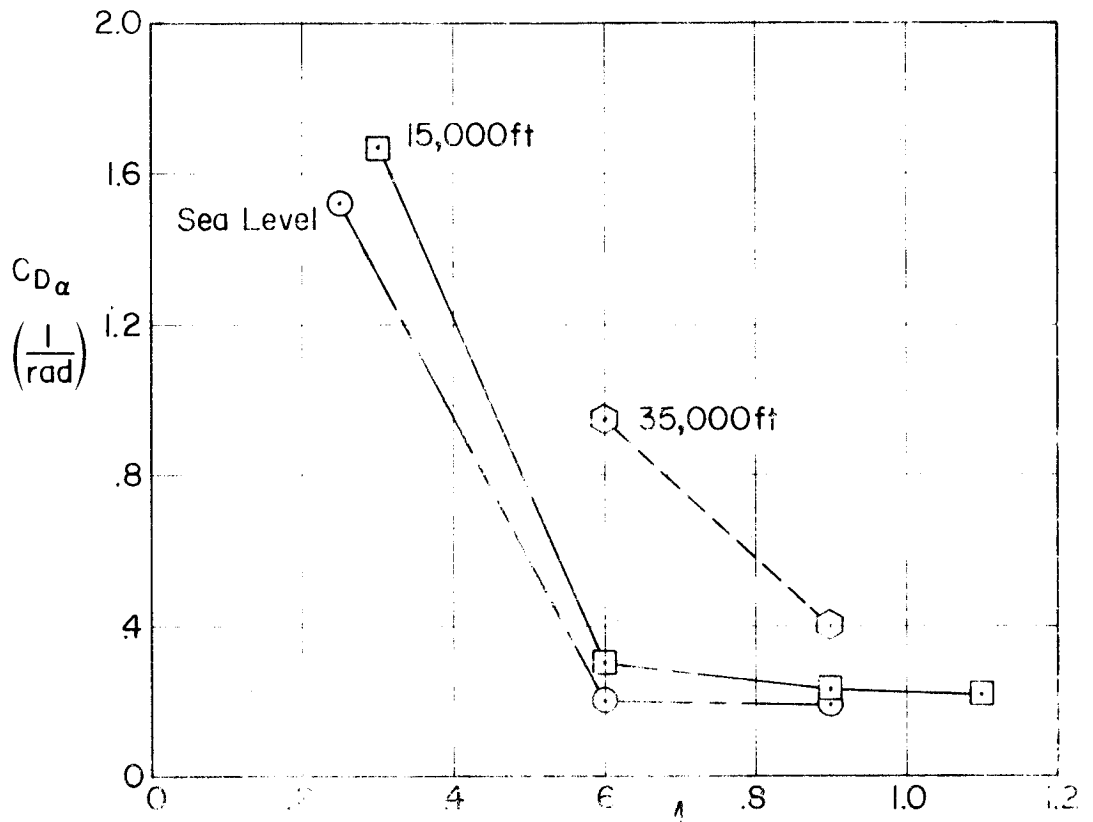
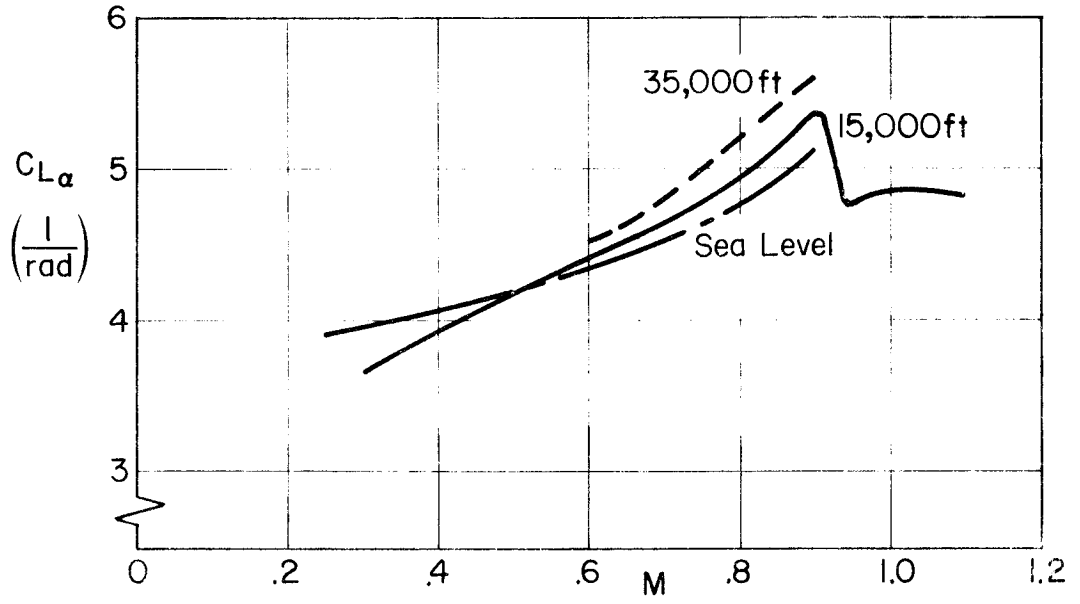
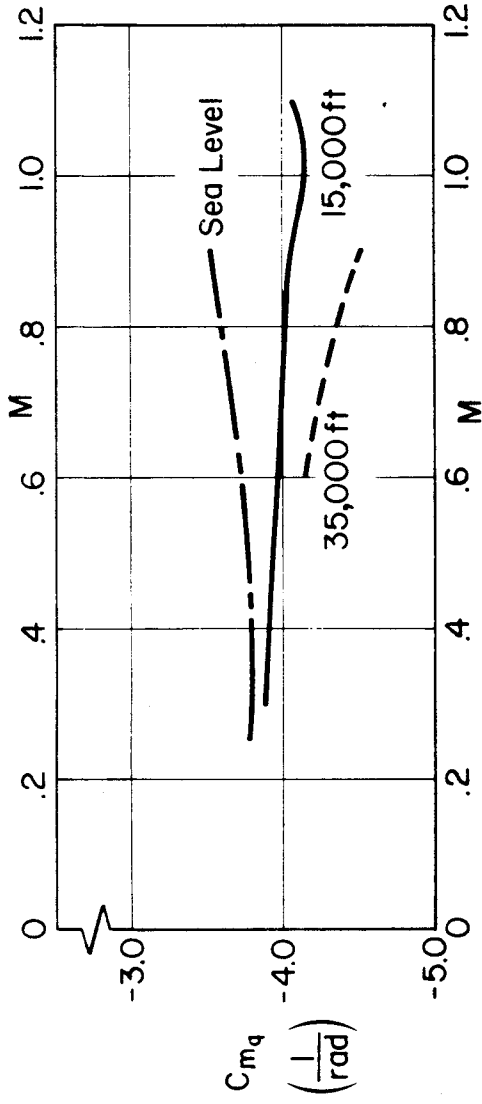
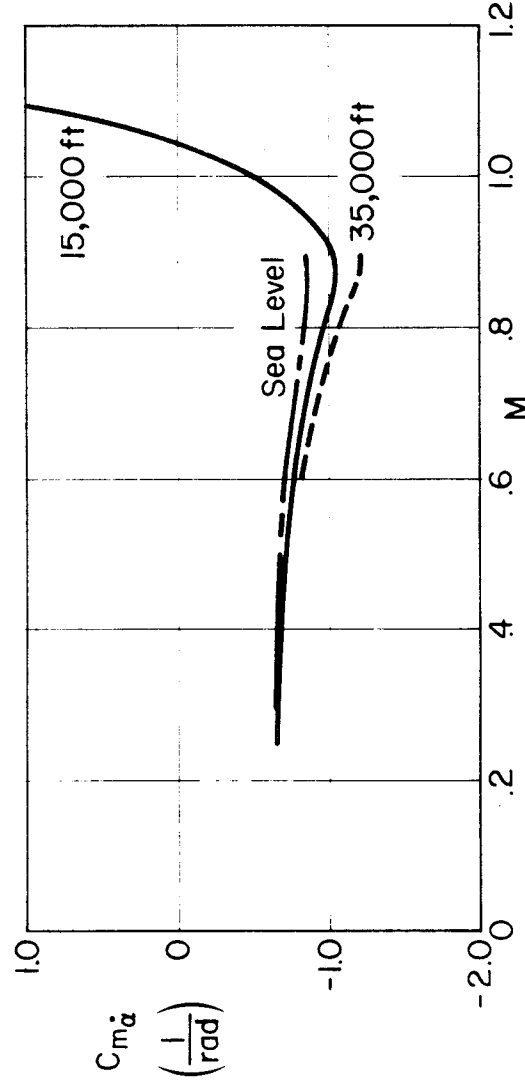
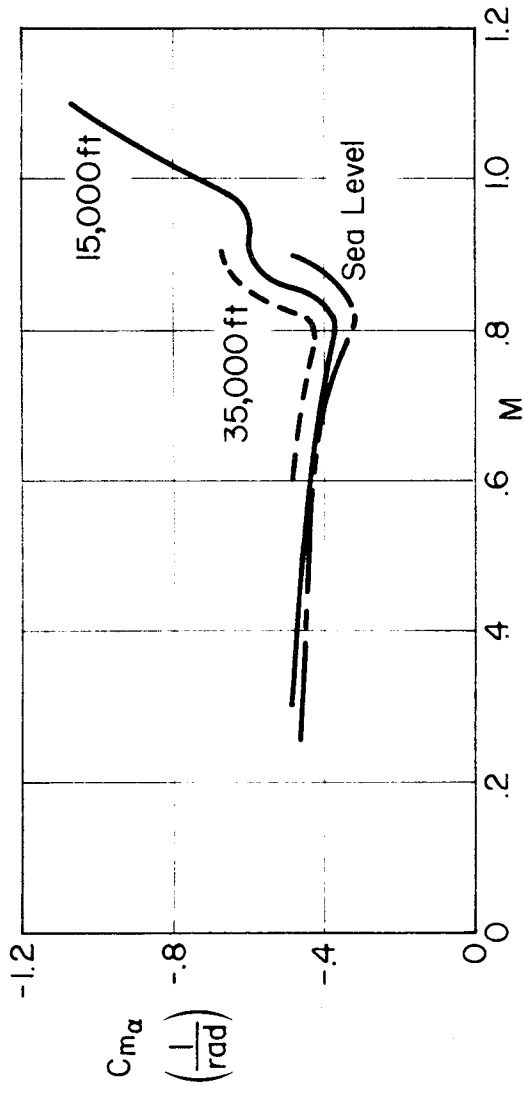


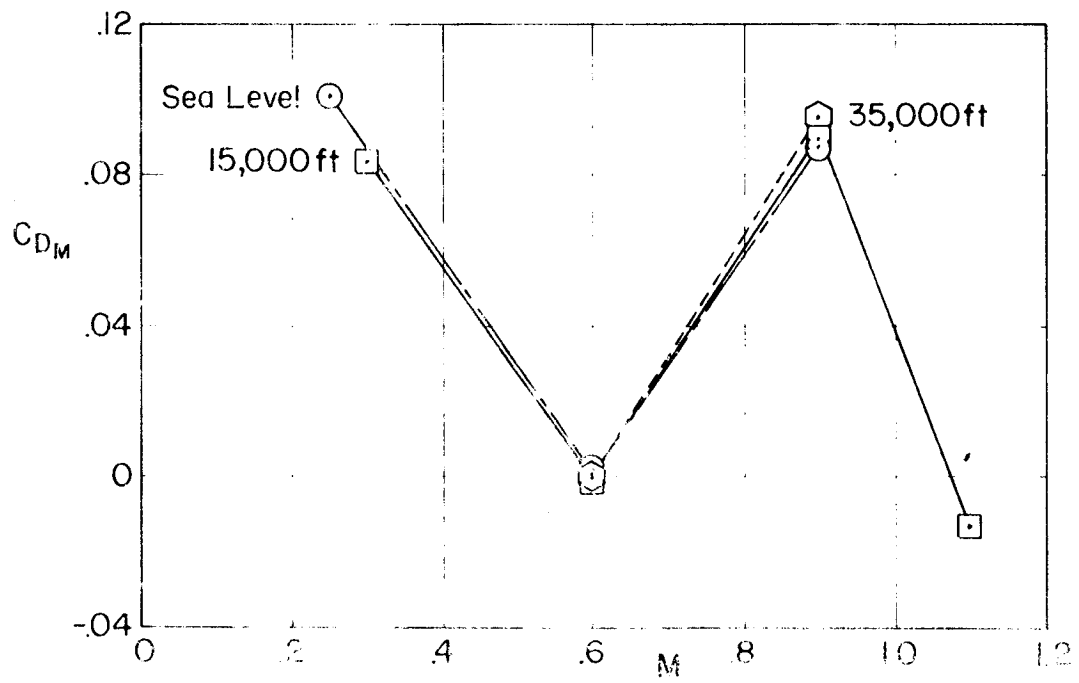
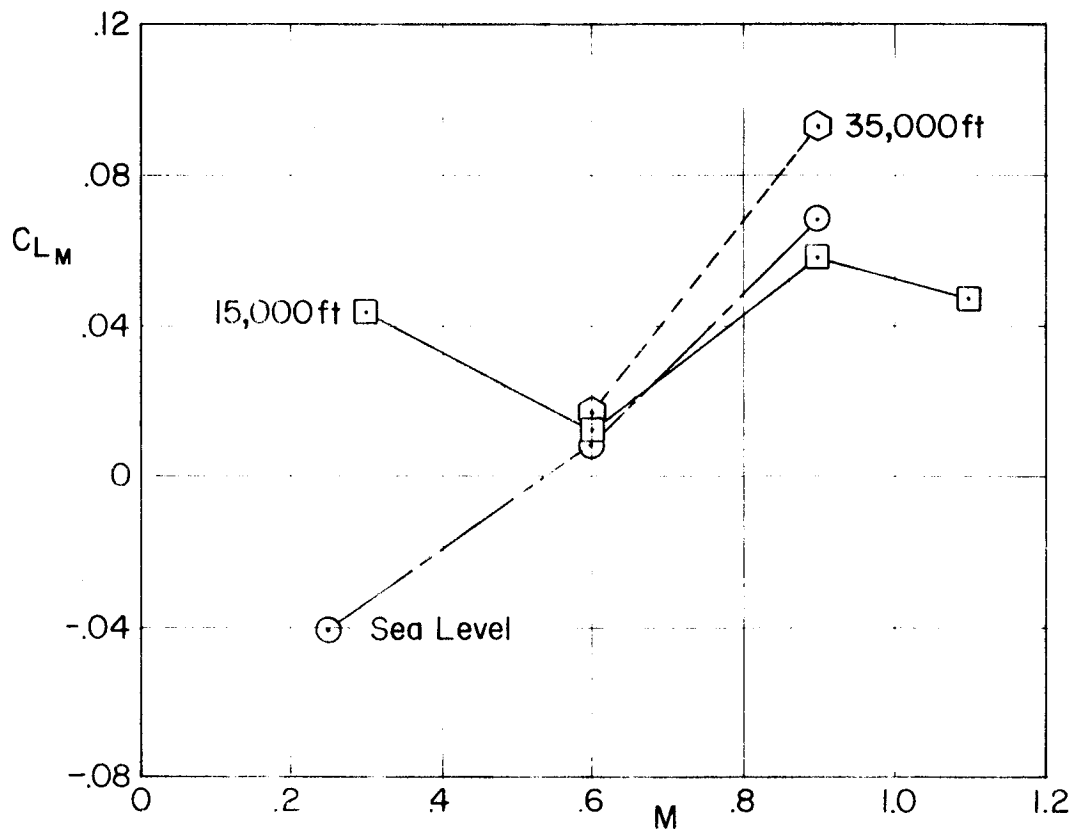
Figure II-2. A-7A Stability Augmentation System

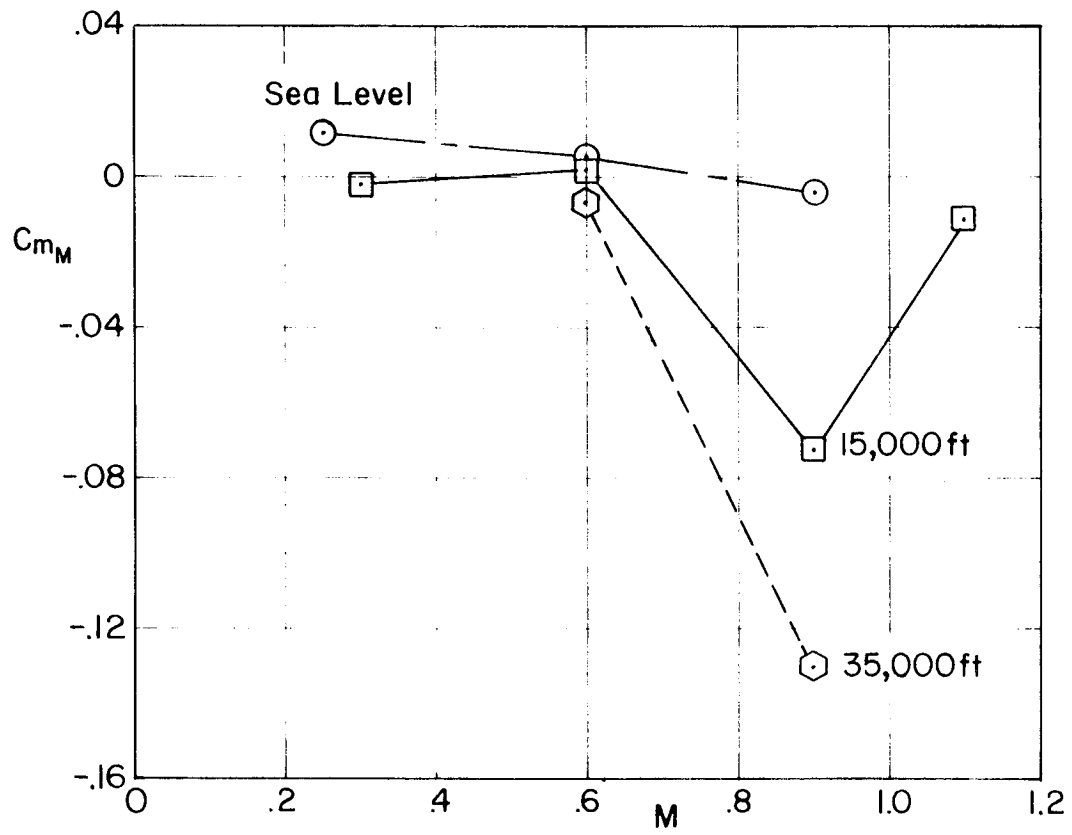


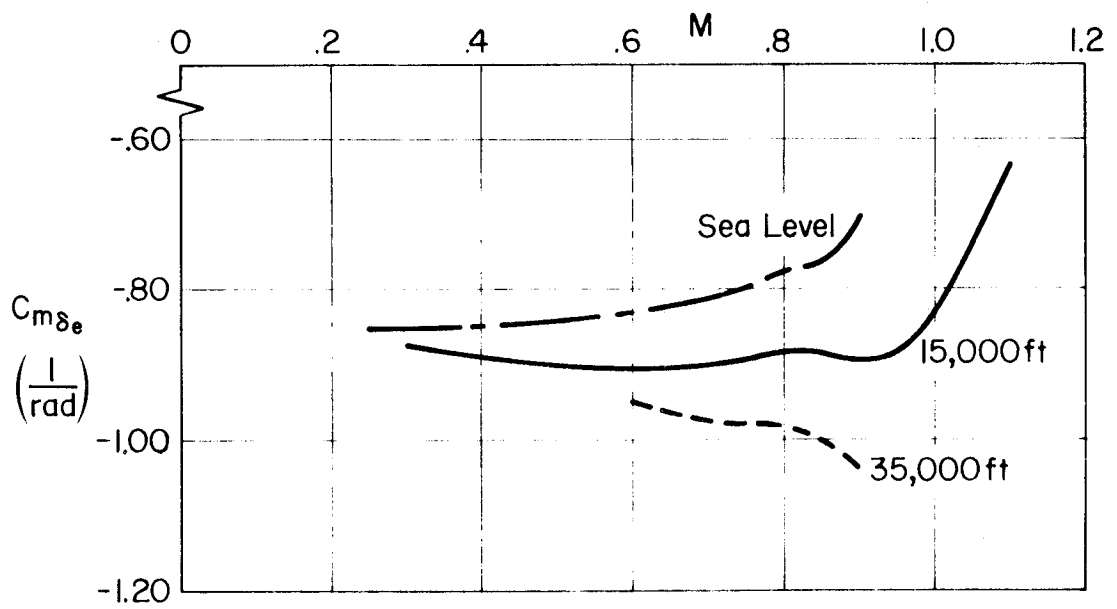
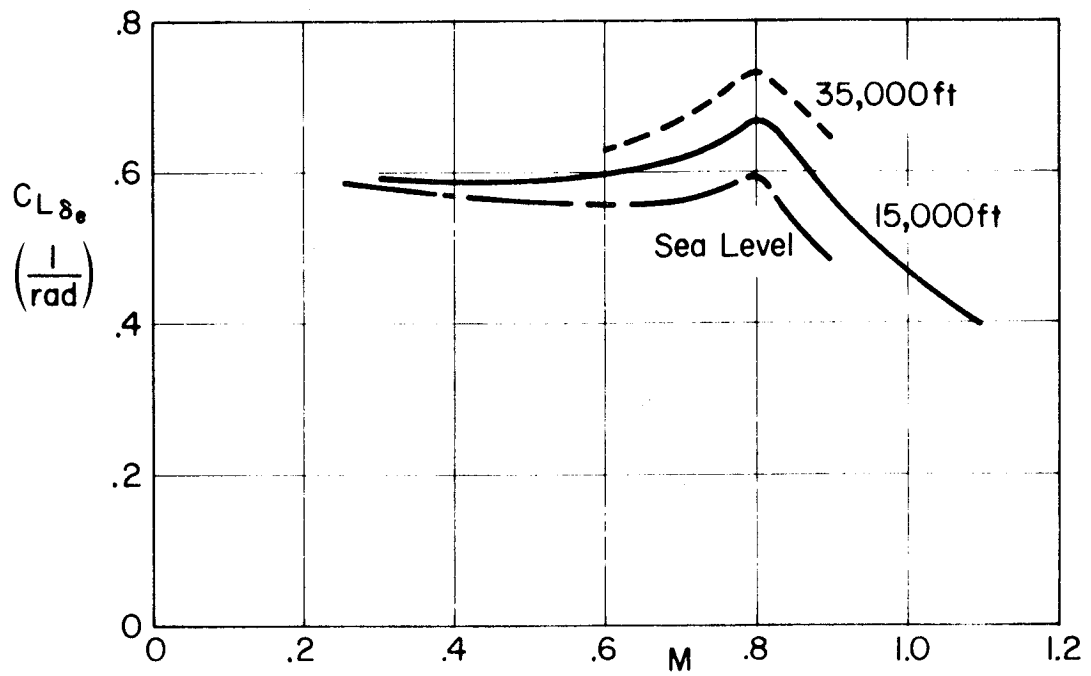


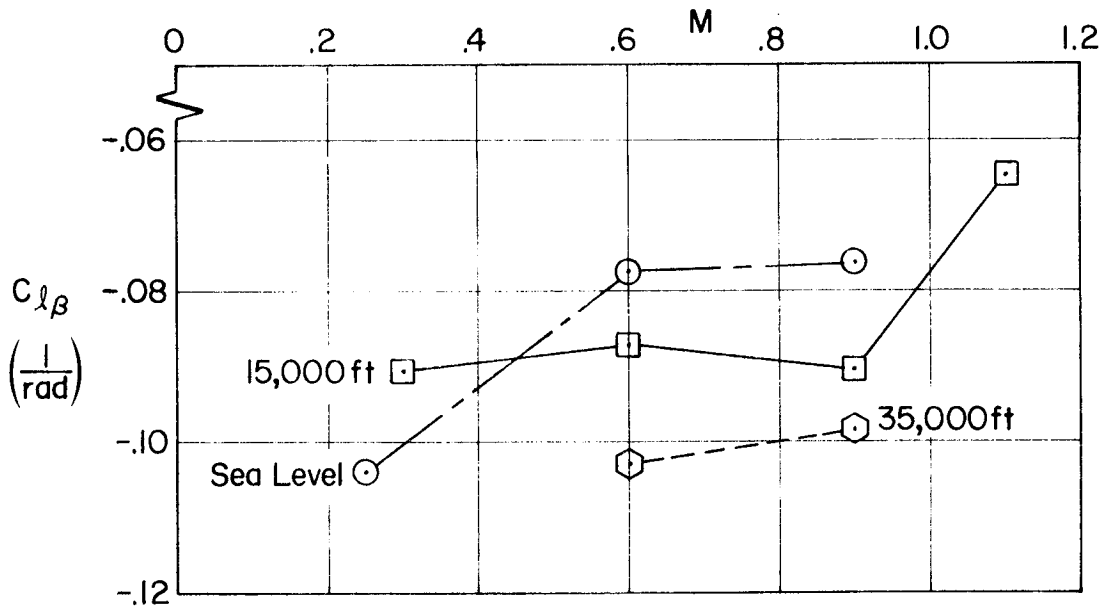
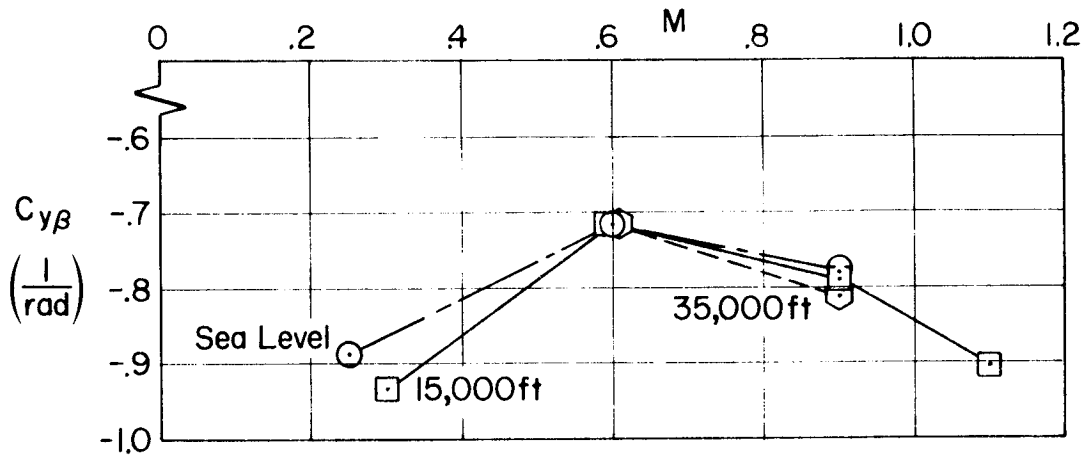


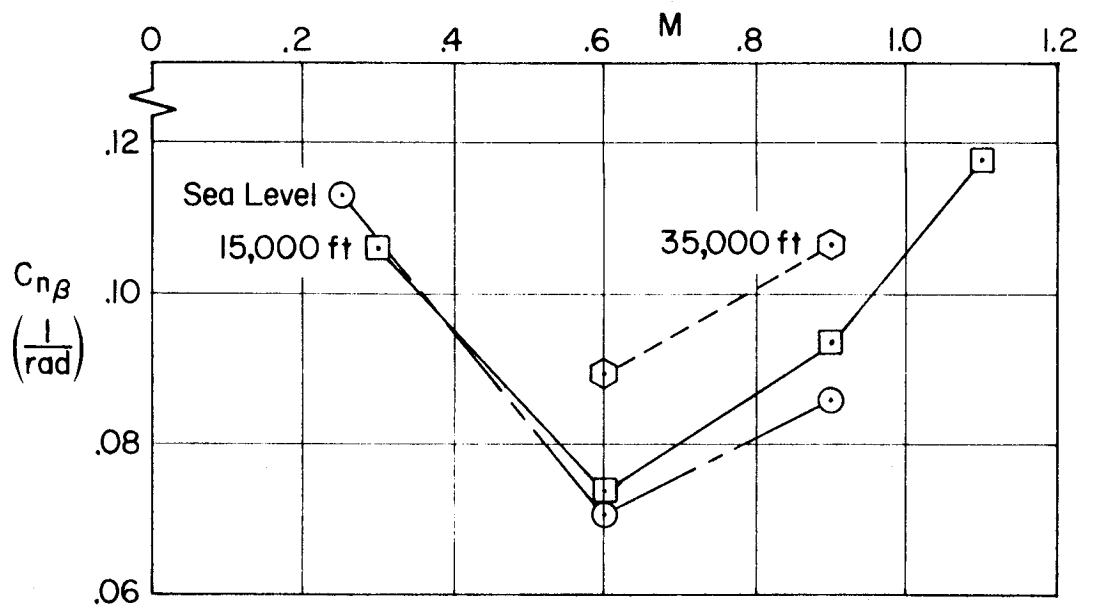


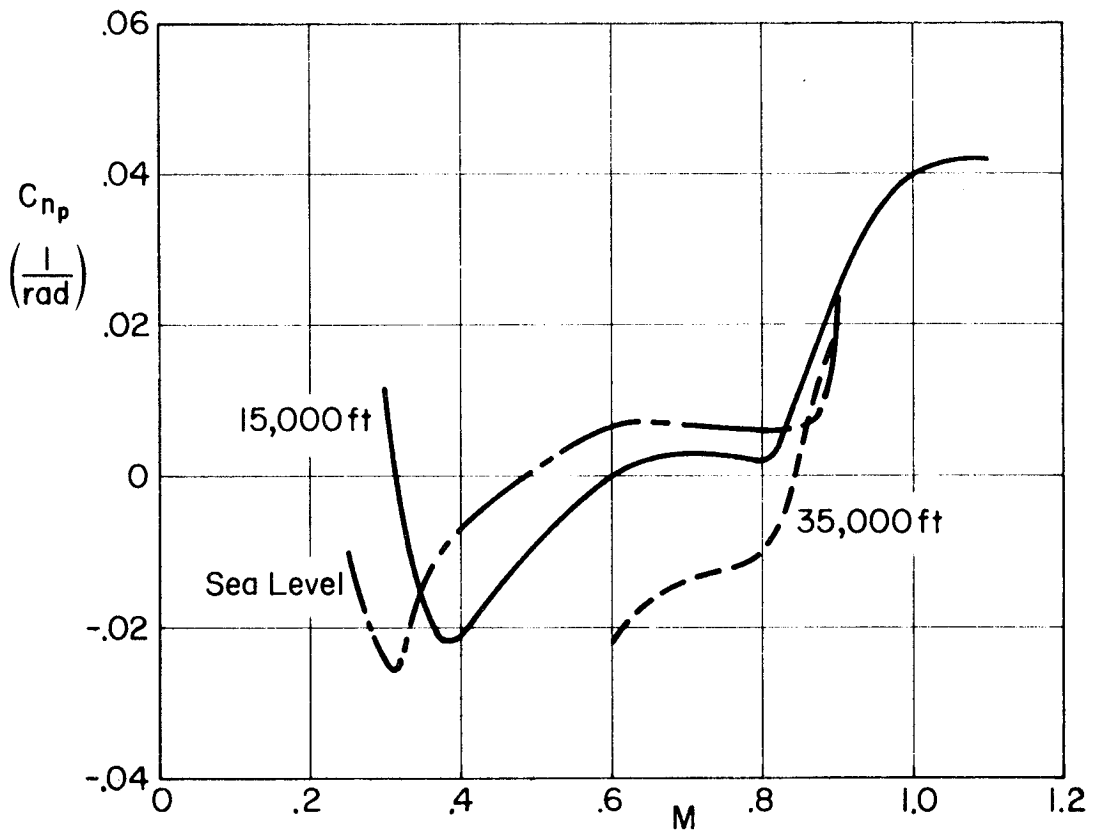
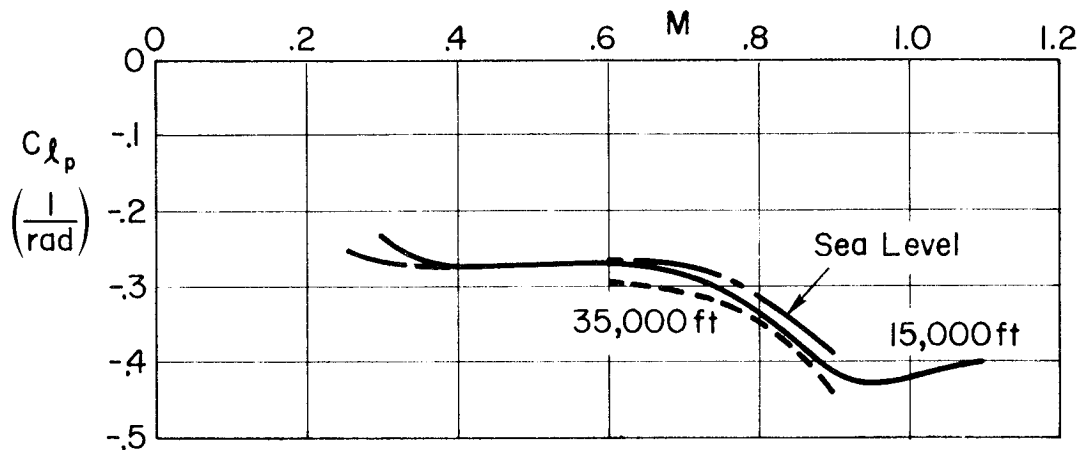


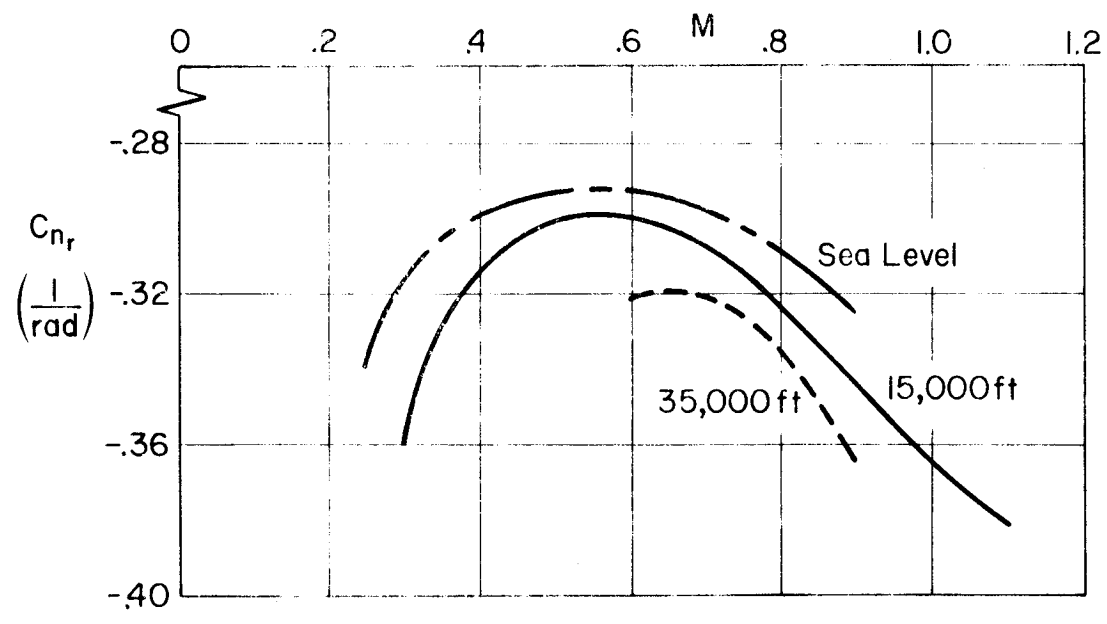
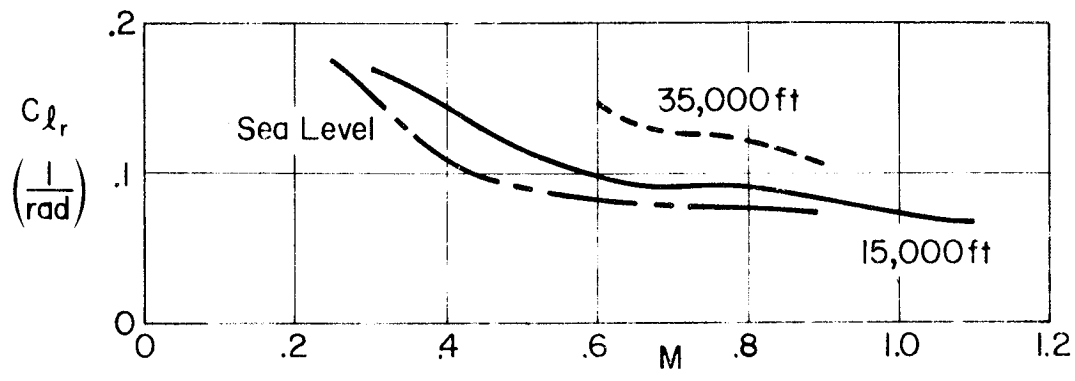


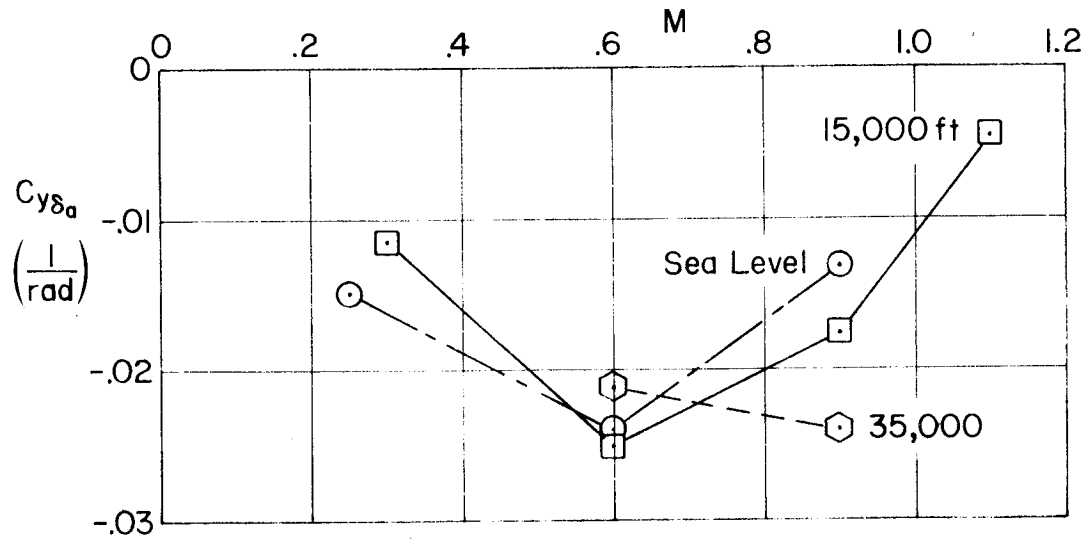




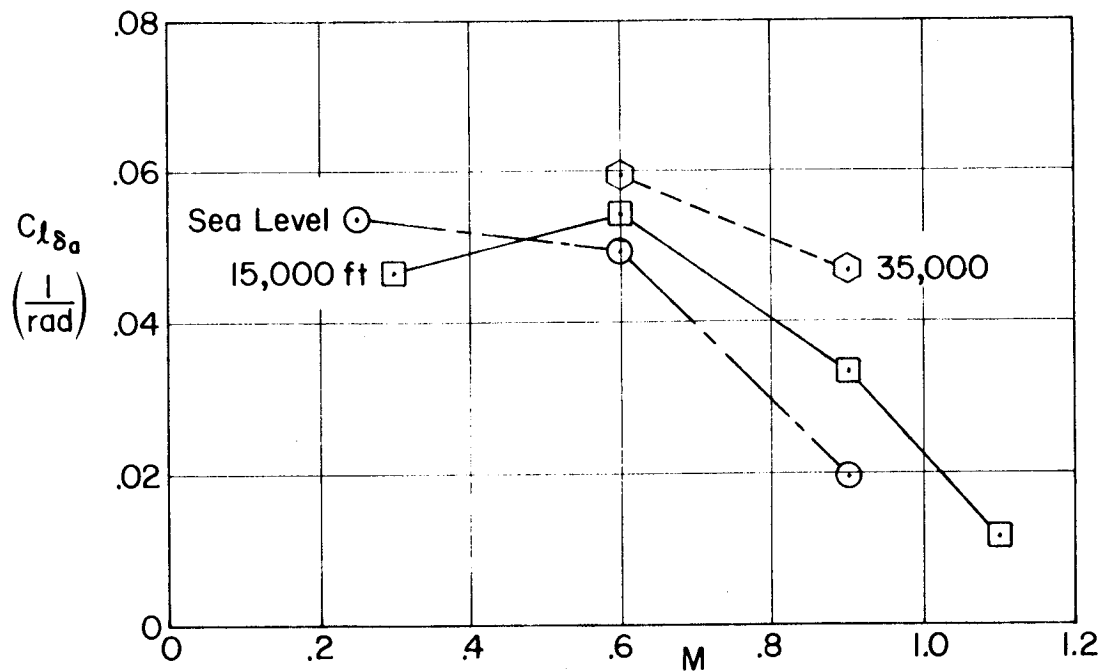


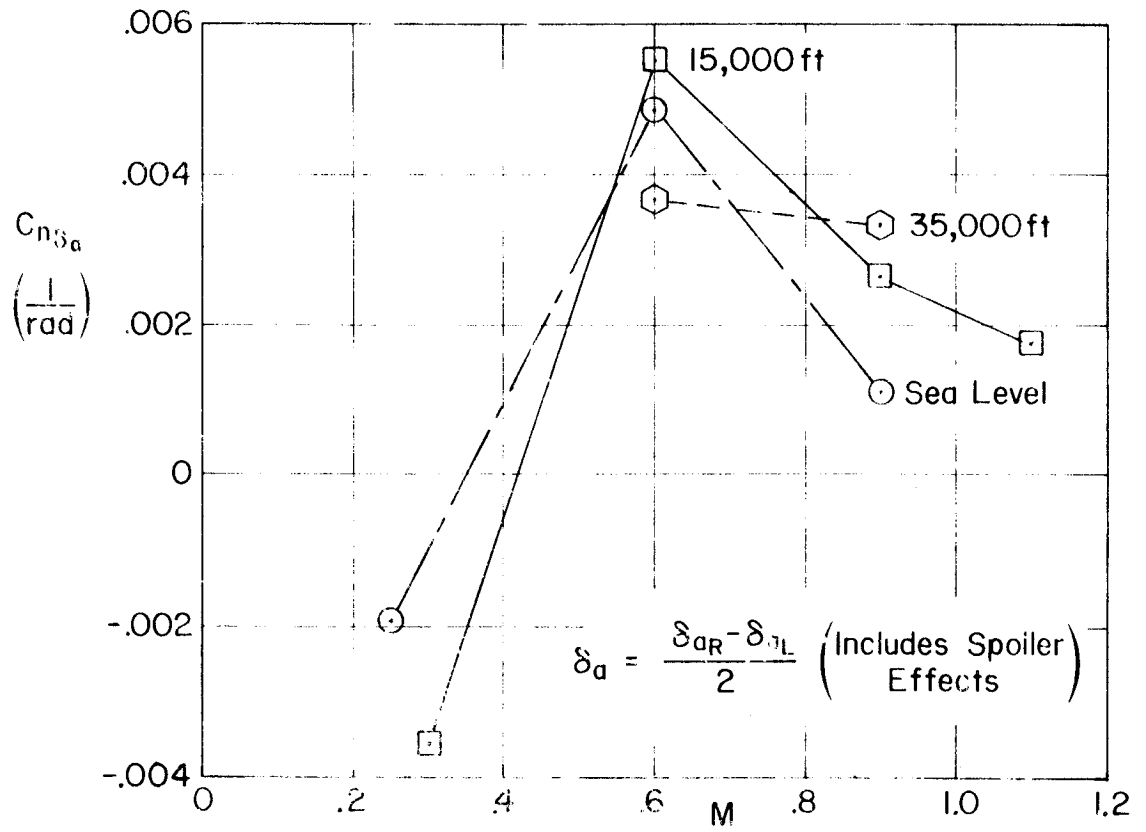


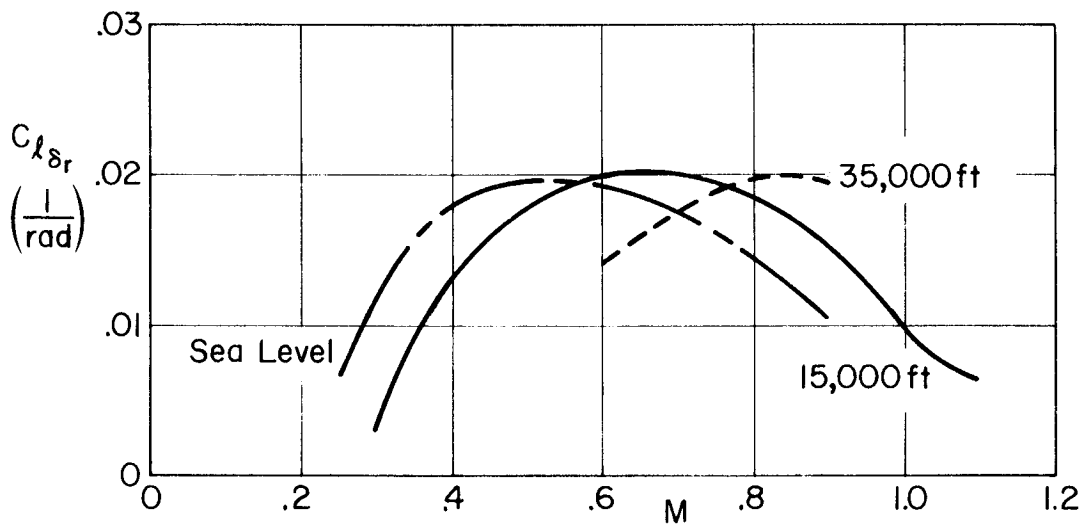
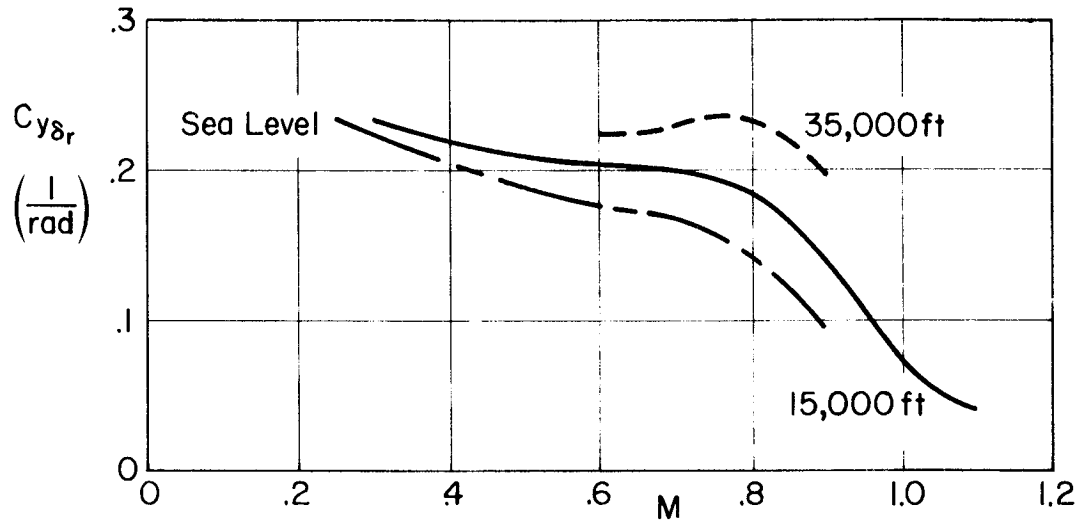




$$\delta_a = \frac{\delta_{aR} - \delta_{aL}}{2} \quad (\text{Includes Spoiler Effects})$$







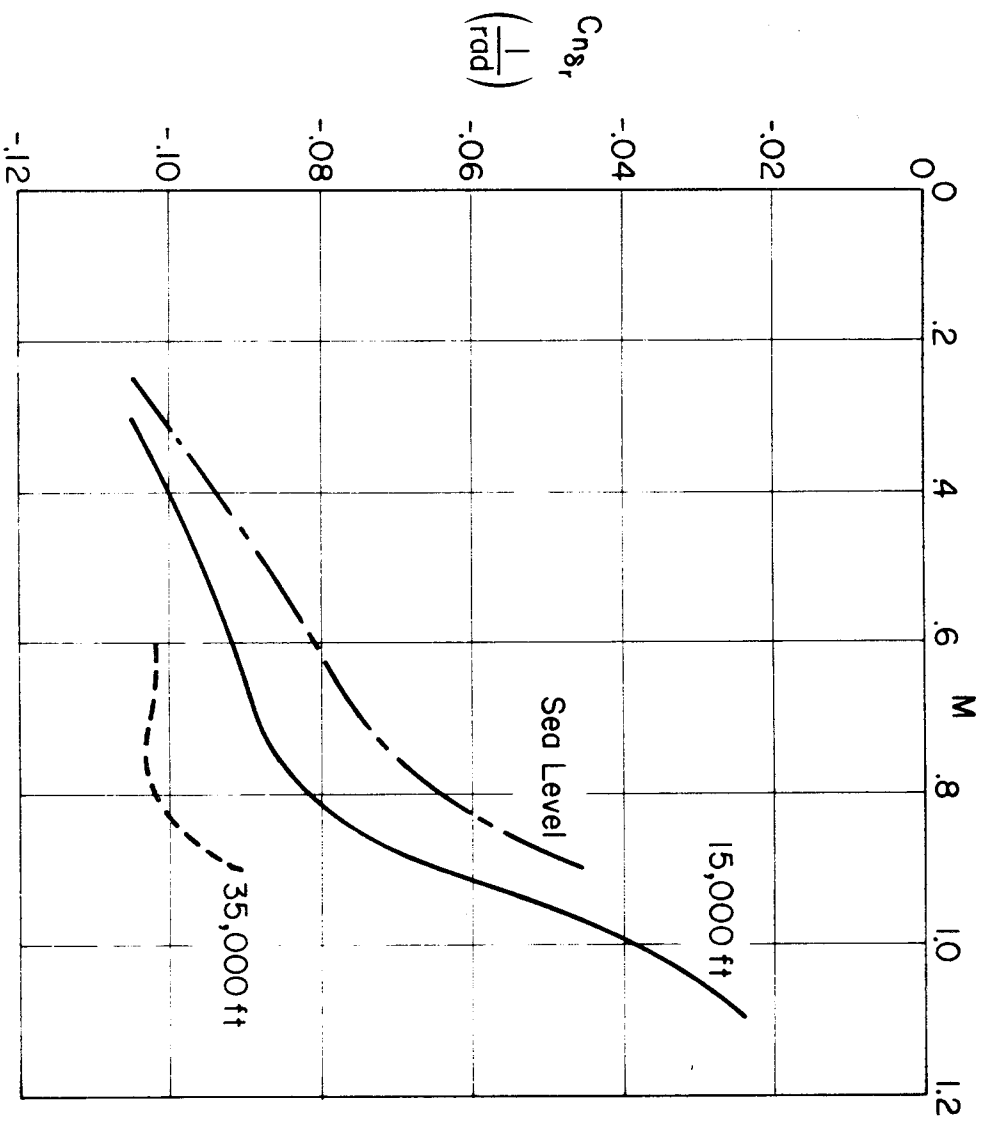


TABLE II-A

GEOMETRICAL PARAMETERS FOR THE A-7A

Note: Data for body-fixed centerline axis, clean flexible airplane

$$S = 375 \text{ ft}^2, \quad b = 38.7 \text{ ft}, \quad c = 10.8 \text{ ft}$$

$$W = 21,889 \text{ lb}, \quad m = 680 \text{ slugs}, \quad \text{c.g. at 30 percent MGC}$$

$$I_x = 13,635 \text{ slug-ft}^2, \quad I_y = 58,966 \text{ slug-ft}^2, \quad I_z = 67,560 \text{ slug-ft}^2, \quad I_{xz} = 2,933 \text{ slug-ft}^2$$

	FLIGHT CONDITION								
	1	2	3	4	5	6	7	8	9
h (ft)	0	0	0	15,000	15,000	15,000	15,000	35,000	35,000
M (-)	0.25	0.6	0.9	0.3	0.6	0.9	1.1	0.6	0.9
a (ft/sec)	1,117	1,117	1,117	1,058	1,058	1,058	1,058	973.3	973.3
ρ (slugs/ft ³)	0.002378	0.002378	0.002378	0.001496	0.001496	0.001496	0.001496	0.000736	0.000736
V_{T_0} (ft/sec)	279	670	1,005	317	635	952	1,164	584	876
$\bar{q} = \rho V_{T_0}^2 / 2$ (lb/ft ²)	91.5	534	1,200	75.3	301	677	1,010	126	283
α_0 (deg)	11.2	2.9	2.1	13.3	4.0	2.5	2.9	7.5	3.8
U_0 (ft/sec)	274	669	1,004	309	633	951	1,163	579	874
W_0 (ft/sec)	54.2	33.9	36.8	72.9	44.3	41.5	58.9	76.2	58.1
δ_{e_0} (deg)	-7.4	-3.35	-3.8	-8.8	-3.8	-3.85	-4.95	-5.4	-4.4
γ_0 (deg)	0	0	0	0	0	0	0	0	0

LONGITUDINAL DIMENSIONAL DERIVATIVES FOR THE A-7A

Note: Data are for body-fixed centerline axis, clean flexible airplane

TABLE II-B

FLIGHT CONDITION									
	1	2	3	4	5	6	7	8	9
h	0	0	0	15,000	15,000	15,000	15,000	35,000	35,000
M	0.25	0.6	0.9	0.3	0.6	0.9	1.1	0.6	0.9
X^w	-0.0145	-0.0568	-0.0284	0.00464	0.0537	0.0339	0.0386	0.0146	0.0316
X_u	0.0162	-0.0123	-0.0732	0.00501	-0.00620	-0.0440	-0.0431	0.00337	-0.0193
$X_{\delta e}$	5.75	8.34	11.6	5.63	6.96	9.13	11.2	5.70	6.61
Z^w	-0.779	-1.92	-3.40	-0.545	-1.16	-2.12	-2.34	-0.554	-1.01
Z_u	-0.0814	-0.00244	0.0184	-0.0857	-0.0244	0.00279	0.0353	-0.0392	-0.0223
$Z_{\delta e}$	-29.0	-165	-318	-23.8	-99.6	-209	-220	-43.2	-99.4
M^w	-0.00982	-0.0232	-0.0402	-0.00777	-0.0143	-0.0292	-0.0639	-0.00711	-0.0150
$M^w_{\delta e}$	-0.000286	-0.000308	-0.000370	-0.000178	-0.000210	-0.000280	+0.000332	-0.000111	-0.000163
M_q	-0.466	-1.11	-1.57	-0.340	-0.696	-1.07	-1.31	-0.330	-0.539
M_u	0.00201	0.00137	0.00118	0.00183	0.00104	-0.00194	0.00245	0.000873	-0.00160
$M_{\delta e}$	-5.44	-30.6	-58.6	-4.52	-18.9	-41.7	-44.2	-8.19	-20.2

TABLE II-C

LATERAL DIMENSIONAL DERIVATIVES FOR THE A-7A

Note: Data are for body-fixed centerline axes, clean flexible airplane

	FLIGHT CONDITION								
	1	2	3	4	5	6	7	8	9
h	0	0	0	15,000	15,000	15,000	15,000	35,000	35,000
M	0.25	0.6	0.9	0.3	0.6	0.9	1.1	0.6	0.9
Y_v	-0.162	-0.314	-0.514	-0.122	-0.187	-0.310	-0.435	-0.0847	-0.145
$Y_{\delta_a}^*$	-0.00274	-0.0105	-0.00857	-0.00150	-0.00655	-0.00691	-0.00216	-0.00267	-0.00427
$Y_{\delta_r}^*$	0.0430	0.0769	0.0626	0.0307	0.0537	0.0550	0.0192	0.0267	0.0347
L'_β	-11.9	-44.8	-98.0	-8.79	-29.2	-66.0	-71.2	-14.9	-30.6
L'_p	-2.00	-4.46	-9.75	-1.38	-2.73	-6.19	-7.31	-1.40	-3.00
L'_r	1.18	1.15	1.38	0.857	0.868	0.843	0.859	0.599	0.563
L'_{δ_a}	5.34	28.4	25.2	3.75	17.6	24.1	12.5	7.96	14.2
L'_{δ_r}	2.22	11.4	13.2	1.82	7.27	11.2	7.27	3.09	6.55
N'_β	1.28	5.74	17.2	0.948	3.12	10.2	21.9	1.38	4.72
N'_p	-0.0870	-0.168	-0.319	-0.0310	-0.116	-0.207	-0.169	-0.0799	-0.112
N'_r	-0.369	-0.905	-1.54	-0.271	-0.541	-0.975	-1.33	-0.247	-0.455
N'_{δ_a}	0.402	2.08	1.56	0.280	1.37	1.64	1.04	0.652	1.01
N'_{δ_r}	-1.93	-8.61	-11.1	-1.56	-5.54	-8.80	-4.83	-2.54	-5.11

IR-176-1

23

TABLE II-D

ELEVATOR LONGITUDINAL TRANSFER FUNCTION FACTORS FOR THE A-7A

Note: Data for body-fixed centerline axes, clean flexible airplane

		FLIGHT CONDITION								
		1	2	3	4	5	6	7	8	9
h		0	0	0	15,000	15,000	15,000	15,000	35,000	35,000
M		0.25	0.6	0.9	0.3	0.6	0.9	1.1	0.6	0.9
Δ	ζ_{sp}	0.367	0.383	0.395	0.277	0.316	0.316	0.185	0.225	0.230
	ω_{sp}	1.76	4.21	6.76	1.63	3.15	5.48	8.81	2.08	3.68
	$\zeta_p (1/T_{p1})$	0.0594	0.100	0.790	0.118	0.0620	(0.0888)	0.589	0.0449	(0.0616)
	$\omega_p (1/T_{p2})$	0.156	0.0698	0.0472	0.140	0.0710	(-0.0513)	0.0372	0.0751	(-0.0501)
θ N_{δ_e}	A_θ	-5.43	-30.6	-58.4	-45.1	-18.8	-41.6	-44.3	-8.18	-20.2
	$1/T_{\theta 1}$	-0.0214	0.0122	0.0728	-0.00823	0.00716	0.0443	0.0422	-0.00316	0.0202
	$1/T_{\theta 2}$	0.731	1.79	3.19	0.506	1.09	1.97	2.02	0.516	0.933
$N_{\delta_2}^{u}$	A_u	5.75	8.34	11.6	5.63	6.96	9.13	11.2	5.70	6.61
	$1/T_{u1}$	51.1	125	186	8.5	120	190	234	109	177
	$\zeta_u (1/T_{u2})$	(0.411)	0.665	(1.22)	(0.369)	0.627	0.854	(0.899)	0.925	0.753
	$\omega_u (1/T_{u3})$	(1.03)	1.30	(2.28)	(0.587)	0.890	1.24	(1.23)	0.466	0.719
$N_{\delta_e}^w$	A_w	-29.0	-165	-318	-23.8	-99.6	-209	-220	-43.2	-99.4
	$1/T_{w1}$	51.7	126	187	58.9	121	191	234	110	178
	$\zeta_w (1/T_{w2})$	-0.110	0.239	(-0.00603)	-0.0444	0.0567	(-0.00939)	(-0.0131)	-0.0553	0.419
	$\omega_w (1/T_{w3})$	0.105	0.0210	(0.0773)	0.0990	0.0386	(0.0518)	(0.0530)	0.0494	0.0219
$N_{\delta_e}^h$	A_h	29.6	165	318	24.5	99.8	209	221	43.6	99.7
	$1/T_{h1}$	-0.0624	0.00956	0.0719	-0.0549	0.00225	0.0431	0.0412	-0.0154	0.0173
	$1/T_{h2}$	6.21	15.6	25.3	5.41	11.8	20.0	22.2	7.64	13.2
	$1/T_{h3}$	-5.57	-14.3	-23.3	-4.92	-11.0	-18.7	-21.2	-7.22	-12.5
$N_{\delta_e}^{az}$ CG	A_{az}	-29.0	-165	-318	-23.8	-99.6	-209	-220	-43.2	-99.4
	$1/T_{az1}$	-0.00998	-0.00248	-0.00117	-0.00417	-0.00405	-0.00147	-0.00139	-0.00170	-0.00250
	$1/T_{az2}$	-0.0506	0.0120	0.0729	-0.0497	0.00627	0.0445	0.0425	-0.0136	0.0197
	$1/T_{az3}$	6.33	15.6	25.3	5.55	11.8	20.0	22.2	7.69	13.2
	$1/T_{az4}$	-5.73	-14.3	-23.3	-5.08	-11.0	-18.7	-21.3	-7.28	-12.5

TABLE II-E

AILERON LATERAL TRANSFER FUNCTION FACTORS FOR THE A-7A

Note: Data for body-fixed centerline axes, clean flexible airplane

		FLIGHT CONDITION								
		1	2	3	4	5	6	7	8	9
h		0	0	0	15,000	15,000	15,000	15,000	35,000	35,000
M		0.25	0.6	0.9	0.3	0.6	0.9	1.1	0.6	0.9
Δ	$1/T_S$	0.0462	0.0411	0.0180	0.0449	0.0435	0.0214	0.0102	0.0319	0.0191
	$1/T_R$	1.62	4.46	9.75	0.968	2.71	6.17	7.15	1.28	2.92
	ζ_d	0.237	0.202	0.218	0.231	0.156	0.175	0.189	0.114	0.128
	ω_d	1.81	2.91	4.68	1.65	2.29	3.66	5.03	1.81	2.58
$N_{\delta_a}^p$	A_p	5.34	28.4	25.2	3.75	17.6	24.1	12.5	7.96	14.2
	$1/T_{p1}$	-0.0219	-0.00234	-0.00113	-0.0232	-0.00347	-0.00144	-0.00137	-0.00718	-0.00241
	ζ_p	0.217	0.217	0.222	0.191	0.173	0.176	0.173	0.122	0.124
	ω_p	1.49	3.05	4.91	1.27	2.34	3.87	5.33	1.62	2.64
$N_{\delta_a}^q$	A_q	5.42	28.5	25.2	3.81	17.7	24.1	12.6	8.04	14.3
	ζ_q	0.210	0.217	0.222	0.183	0.173	0.177	0.175	0.119	0.124
	ω_q	1.51	3.05	4.91	1.29	2.34	3.87	5.32	1.62	2.64
$N_{\delta_a}^r$	A_r	0.402	2.08	1.56	0.280	1.37	1.64	1.04	0.652	1.01
	$1/T_{r1}$	0.596	1.12	1.13	0.445	0.777	0.944	0.581	0.420	0.593
	ζ_r	0.0852	0.287	0.597	0.146	0.151	0.446	0.638	0.0198	0.193
	ω_r	2.35	2.29	3.26	2.18	2.13	2.78	3.98	2.03	2.45
$N_{\delta_a}^b$	A_b	-0.00274	-0.0105	-0.00857	-0.00150	-0.00655	-0.00691	-0.00216	-0.00267	-0.00427
	$1/T_{b1} (\zeta_b)$	(0.885)	3.26	7.76	(0.726)	2.21	5.77	10.7	0.793	(0.872)
	$1/T_{b2} (\omega_b)$	(0.667)	-0.627	-0.254	(0.471)	-1.63	-0.245	-0.113	0.422	(10.6)
	$1/T_{b3}$	-233	63.1	78.2	-391	23.2	86.8	188	-147	-0.545
CG $N_{\delta_a}^{a_y}$	A_{a_y}	-0.766	-7.06	-8.61	-0.477	-4.16	-6.58	-2.51	-1.56	-0.0374
	$1/T_{a_y1} (\zeta_{a_y2})$	(0.943)	2.29	-1.16	(0.758)	1.32	-0.596	-0.146	0.290	(0.801)
	$1/T_{a_y2} (\omega_{a_y2})$	(0.648)	5.92	-1.84	(0.461)	3.12	-2.66	-7.93	0.961	(2.34)
	$\zeta_{a_y} (1/T_{a_y3})$	0.0396	-0.810	(3.65)	0.0673	-0.294	(3.79)	0.897	0.0499	-0.113
	$\omega_{a_y} (1/T_{a_y4})$	6.37	1.76	(10.7)	7.10	1.99	(-6.63)	9.31	3.92	1.30

TABLE II-F

RUDDER LATERAL TRANSFER FUNCTION FACTORS FOR THE A-7A

Note: Data for body-fixed centerline axes, clean flexible airplane

		FLIGHT CONDITION								
		1	2	3	4	5	6	7	8	9
h		0	0	0	15,000	15,000	15,000	15,000	35,000	35,000
M		0.25	0.6	0.9	0.3	0.6	0.9	1.1	0.6	0.9
Δ	$1/T_s$	0.0462	0.0411	0.0180	0.0419	0.0435	0.0214	0.0102	0.0319	0.0191
	$1/T_R$	1.62	4.46	9.75	0.968	2.71	6.17	7.15	1.28	2.92
	ζ_d	0.237	0.202	0.218	0.231	0.156	0.175	0.189	0.114	0.128
	ω_d	1.81	2.91	4.63	1.65	2.29	3.66	5.03	1.81	2.58
$N_{\delta_r}^p$	A_p	2.22	11.4	13.2	18.2	7.27	11.2	7.27	3.09	6.55
	$1/T_{p1}$	-0.0224	-0.00242	-0.00117	-0.0237	-0.00352	-0.00147	-0.00141	-0.00723	-0.00243
	$1/T_{p2}$	2.68	5.35	8.31	2.33	4.31	6.63	5.56	3.16	4.39
	$1/T_{p3}$	-3.38	-5.31	-7.88	-2.79	-4.45	-6.33	-4.55	-3.44	-4.38
$N_{\delta_r}^\phi$	A_ϕ	1.84	10.9	12.8	1.45	6.89	10.8	7.03	2.75	6.21
	$1/T_{\phi 1}$	2.78	5.37	8.29	2.48	4.35	6.64	5.53	3.27	4.43
	$1/T_{\phi 2}$	-4.11	-5.53	-8.18	-3.48	-4.68	-6.57	-4.76	-3.79	-4.61
$N_{\delta_r}^r$	A_r	-1.93	-8.61	-11.1	-1.56	-5.54	-8.80	-4.83	-2.54	-5.11
	$1/T_{r1}$	1.13	4.33	9.87	0.553	2.35	6.12	7.31	0.578	2.64
	ζ_r	0.538	0.475	0.674	0.414	0.473	0.535	0.790	0.440	0.526
	ω_r	1.02	0.642	0.502	1.17	0.735	0.541	0.381	1.12	0.585
$N_{\delta_r}^\beta$	A_β	0.0430	0.0769	0.0626	0.0307	0.0537	0.0550	0.0192	0.0267	0.0347
	$1/T_{\beta 1}$	-0.0624	-0.00199	0.000266	-0.0603	-0.00616	0.000578	0.00271	-0.0178	-0.00216
	$1/T_{\beta 2}$	1.73	4.45	9.76	1.14	2.70	6.17	7.11	1.32	2.94
	$1/T_{\beta 3}$	54.7	120	186	63.6	113	170	272	110	160
$N_{\delta_r}^{a_y}$ CG	A_{a_y}	12.0	51.5	62.9	9.74	34.1	52.3	22.4	15.6	30.4
	$1/T_{a_y 1}$	-0.123	-0.0145	-0.00502	-0.108	-0.0227	-0.00654	0.000648	-0.0436	-0.0107
	$1/T_{a_y 2}$	1.87	4.43	9.57	1.27	2.69	6.16	7.06	1.36	2.97
	$1/T_{a_y 3}$	-2.00	-4.97	-7.84	-1.96	-3.69	-5.78	-8.91	-2.28	-3.81
	$1/T_{a_y 4}$	2.60	5.92	9.57	2.45	4.30	6.80	10.5	2.61	4.30

SECTION III

A-4D

Figure III-1

A-4D

NOMINAL CRUISE CONFIGURATION

Clean Airplane

W = 17,578 lbs

CG at 25% MGC

$I_x = 8090 \text{ slug-ft}^2$

$I_y = 25,900 \text{ slug-ft}^2$

$I_z = 29,200 \text{ slug-ft}^2$

$I_{xz} = 1300 \text{ slug-ft}^2$

} Body
Ref.
Axes

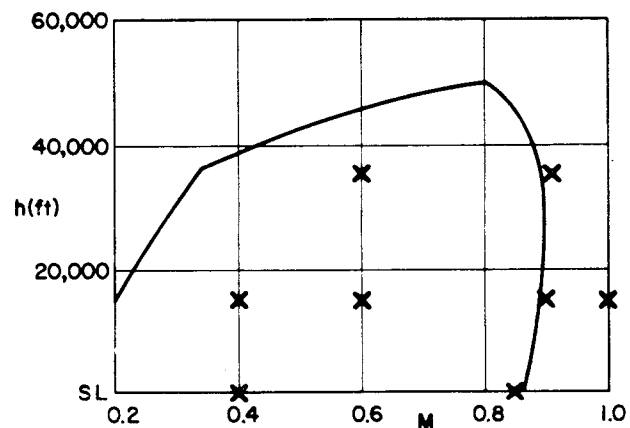
REFERENCE GEOMETRY

S = 260 ft²

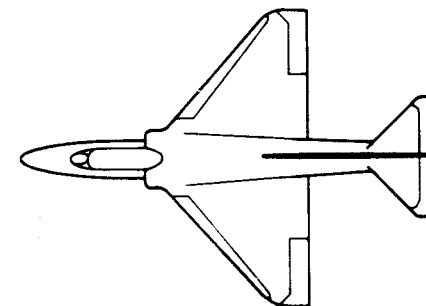
c = 10.8 ft

b = 27.5 ft

FLIGHT ENVELOPE

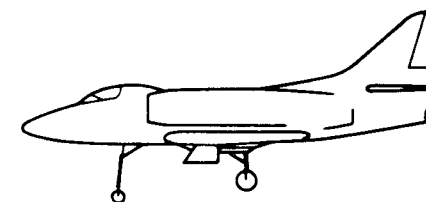
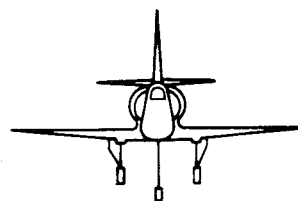


— Envelope for model A-4D-1
 X Transfer functions given for these flight condition



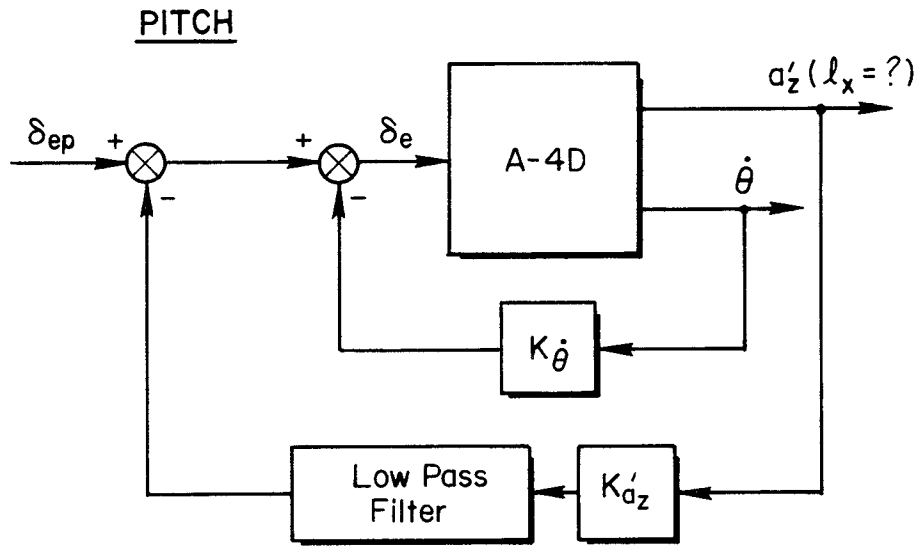
REFERENCES

- 1) Abzug, M.J. and R.L. Faith, Aerodynamic Data for Model A4D-1 Operational Flight Trainer, Douglas Aircraft Co. Report ES-26104, November 1, 1955
- 2) Johnston, D.E. and D.H. Weir, Study of Pilot-Vehicle-Controller Integration for A Minimum Complexity AFCS, Systems Technology, Inc. Technical Report No. 127-1, July 1964



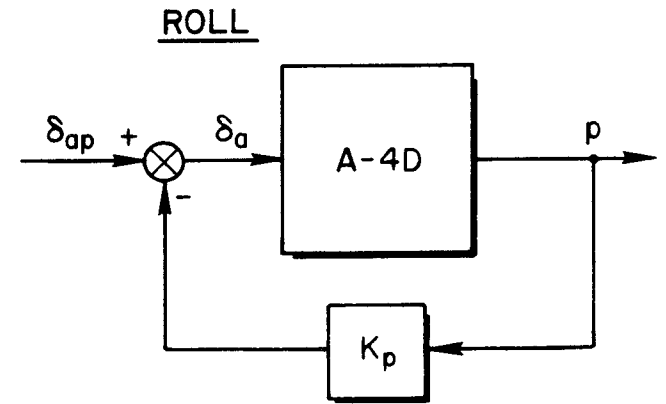
BASIC DATA SOURCES

Wind Tunnel Test

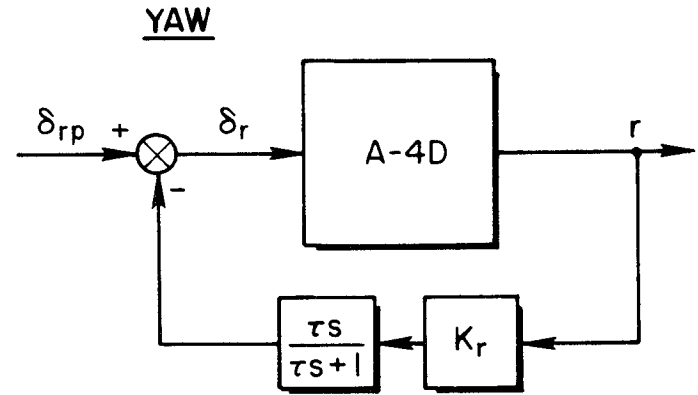


$K_{\dot{\theta}}$, K'_{a_z} : Scheduled for indicated airspeed

Note:
 System used on the A4D-2N model only.
 Control stick steering mode shown

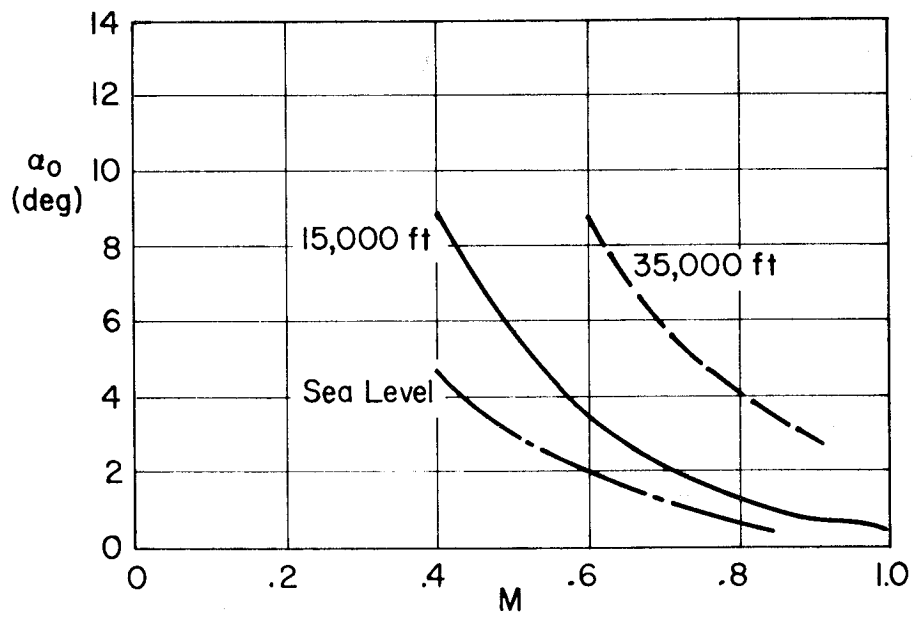


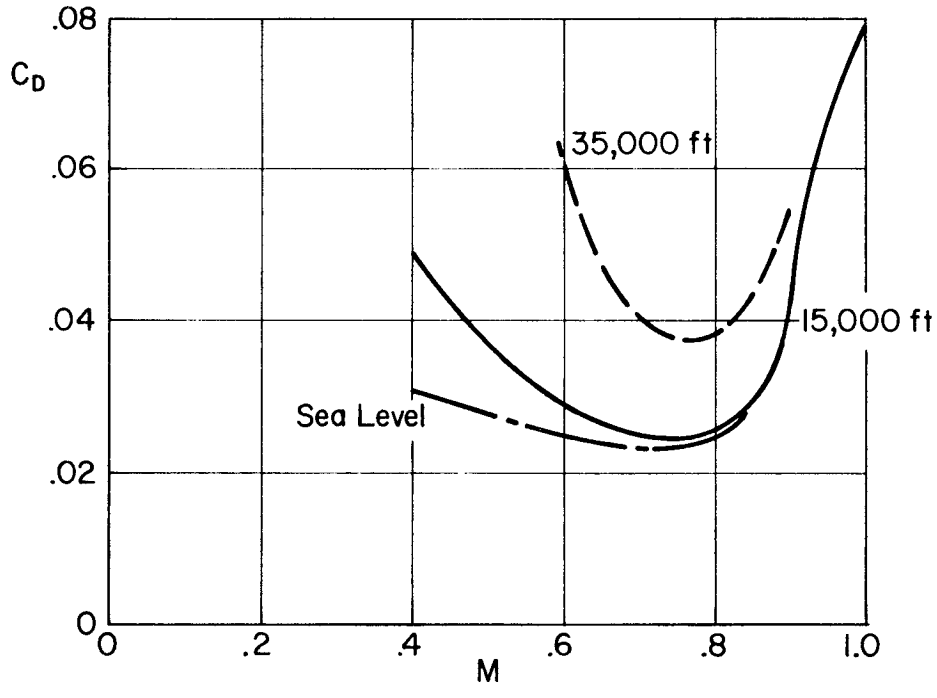
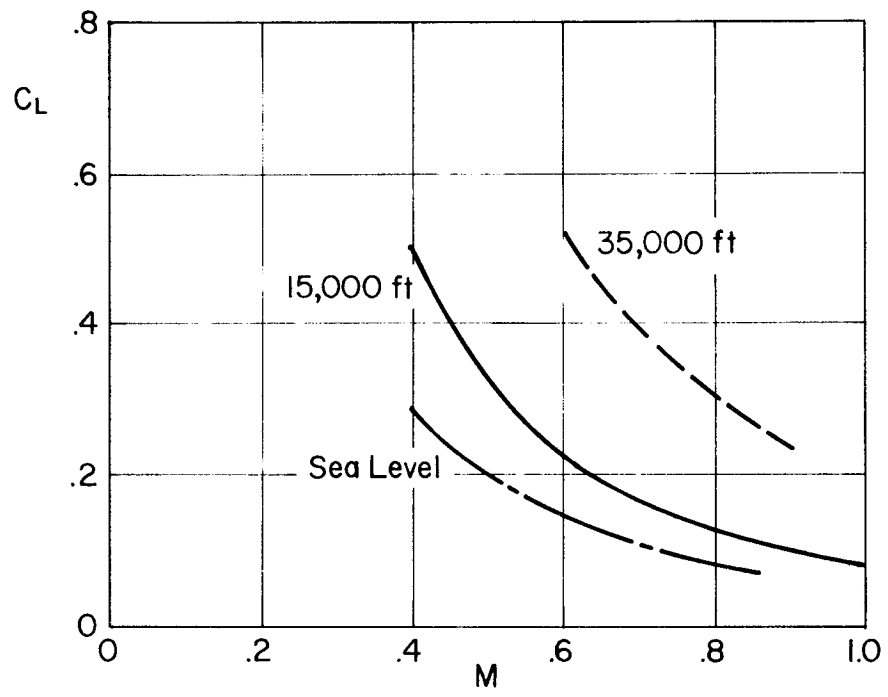
K_p : Gain in deg/deg/sec, scheduled for indicated air speed

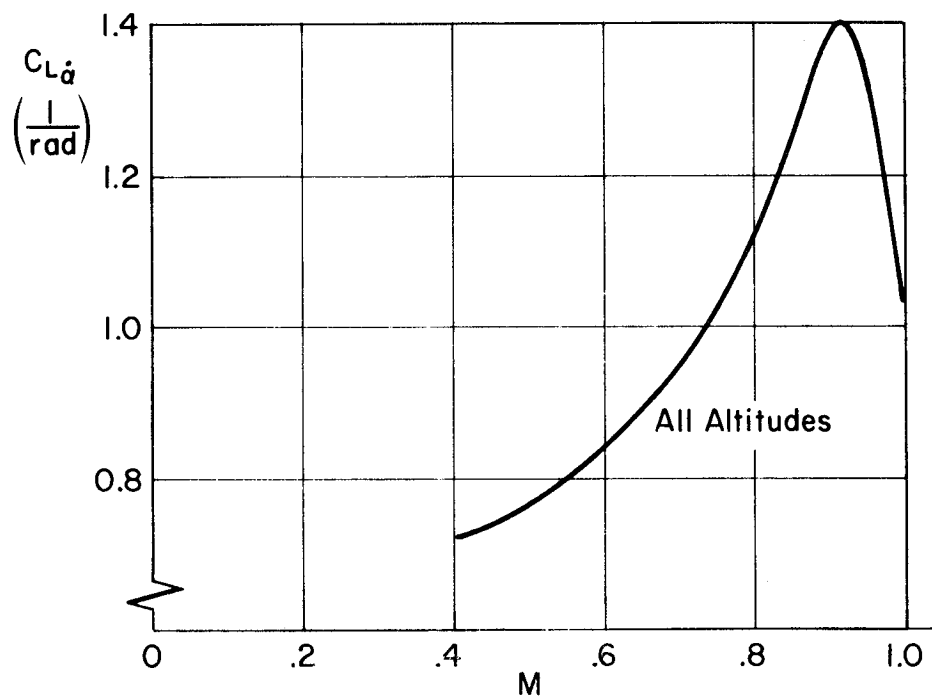
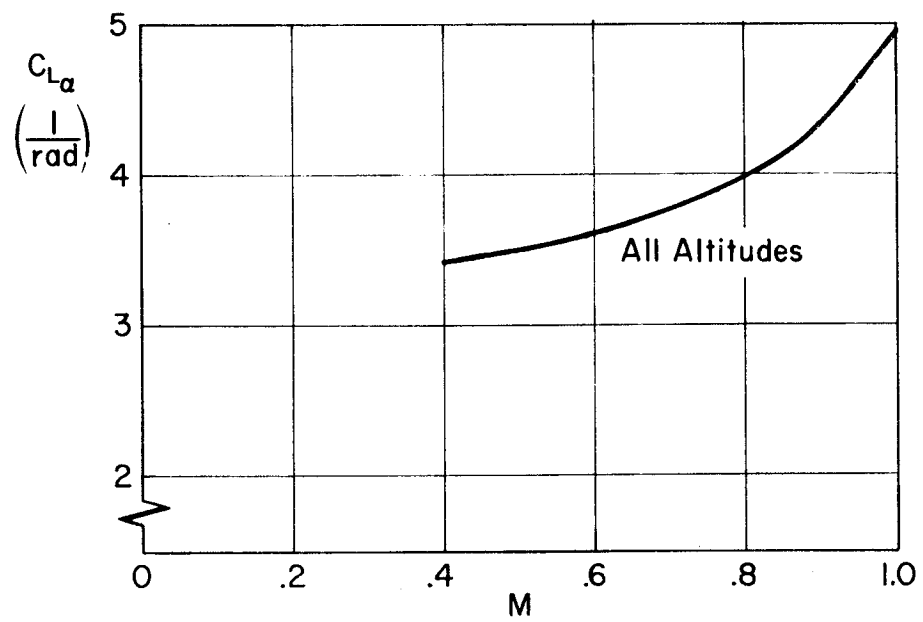


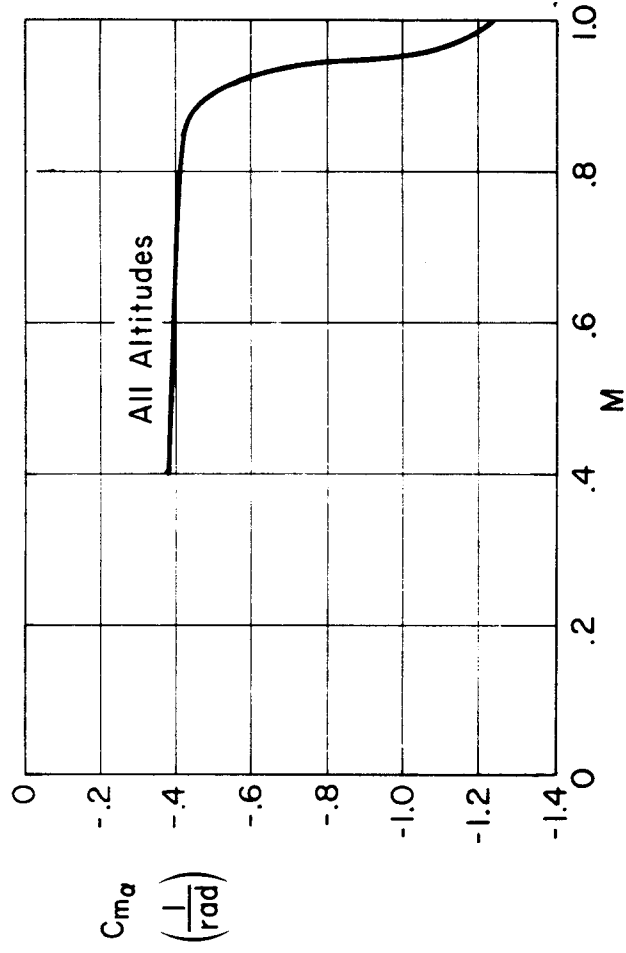
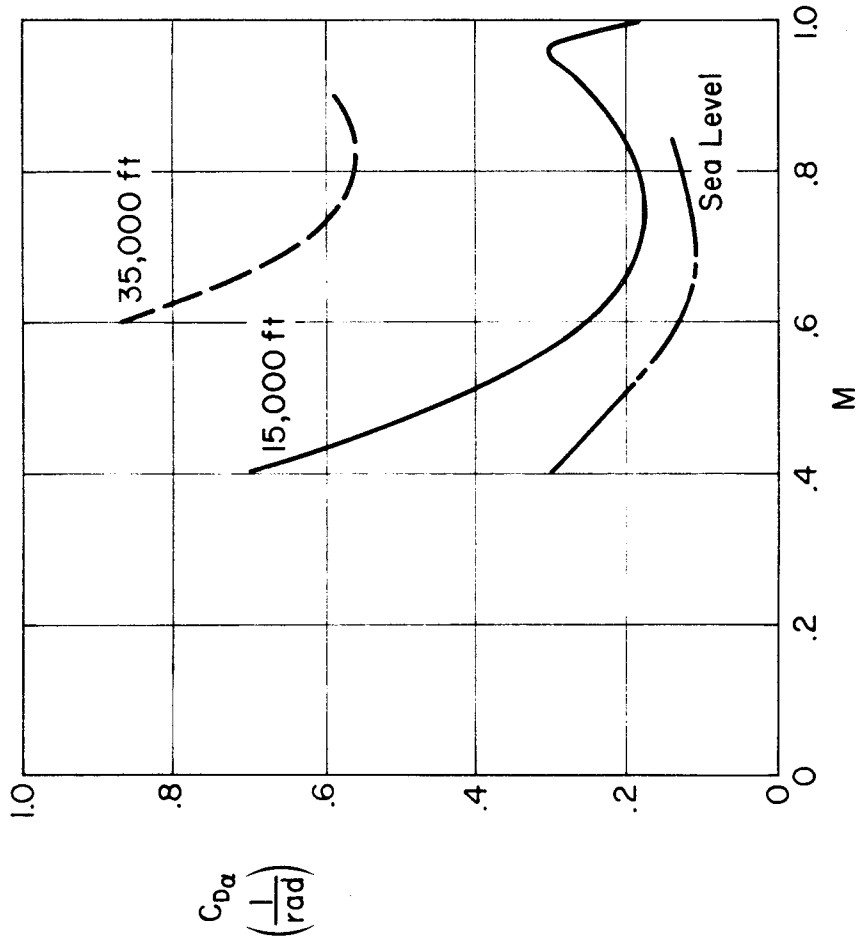
K_r : Gain in deg/deg/sec, scheduled for indicated air speed

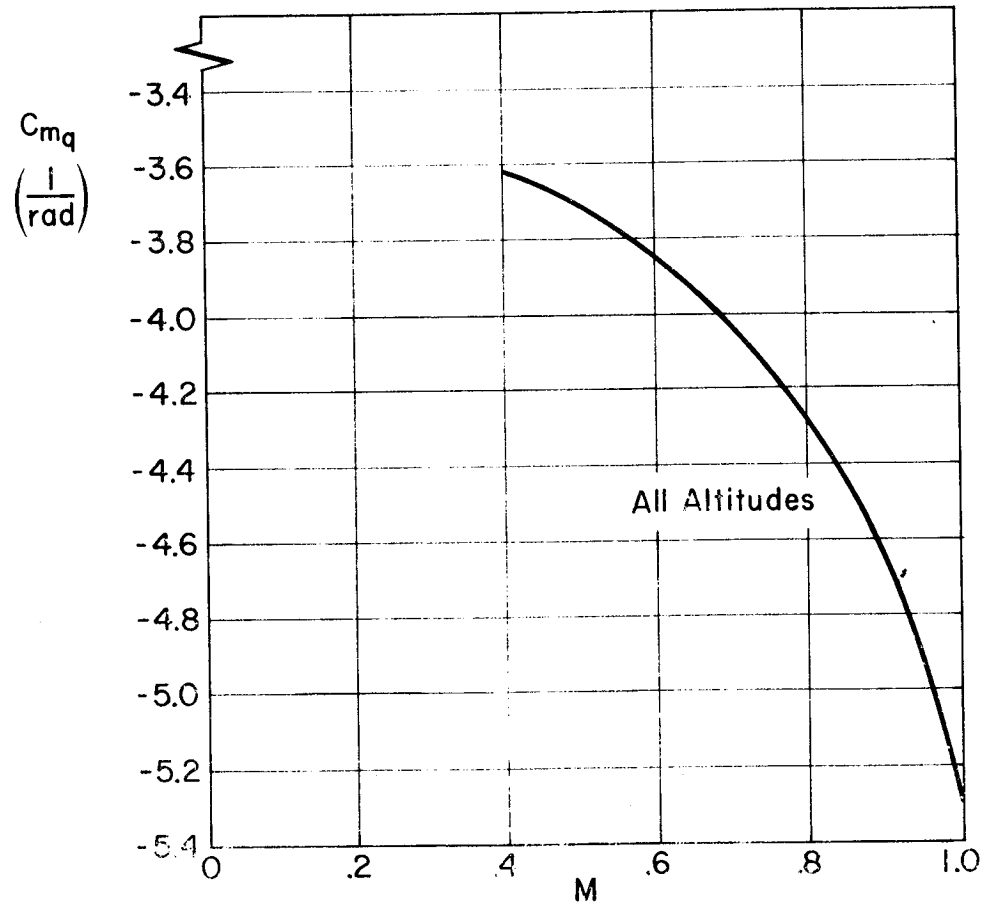
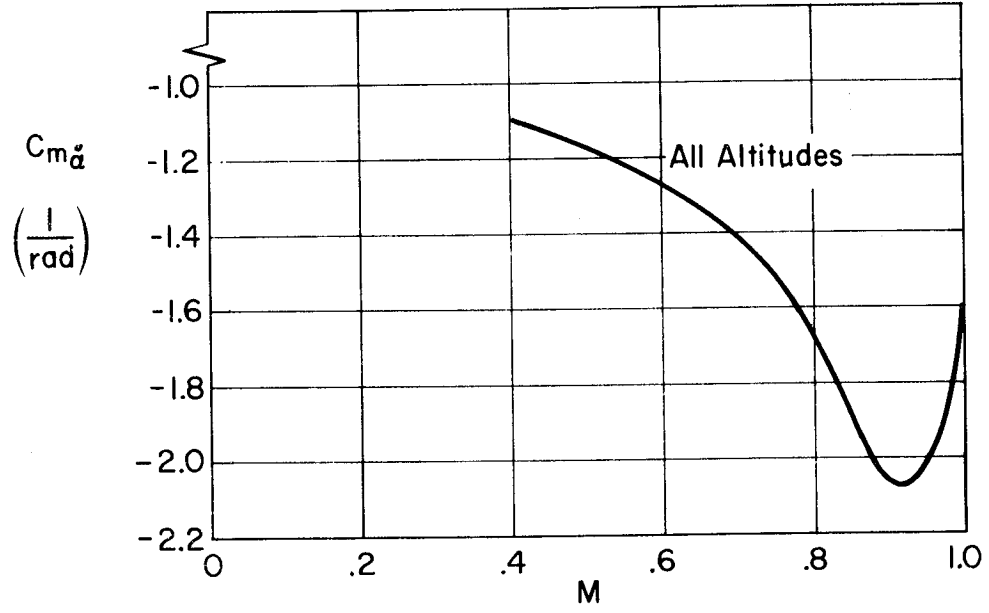
Figure III-2. A-4D — Stability Augmentation System

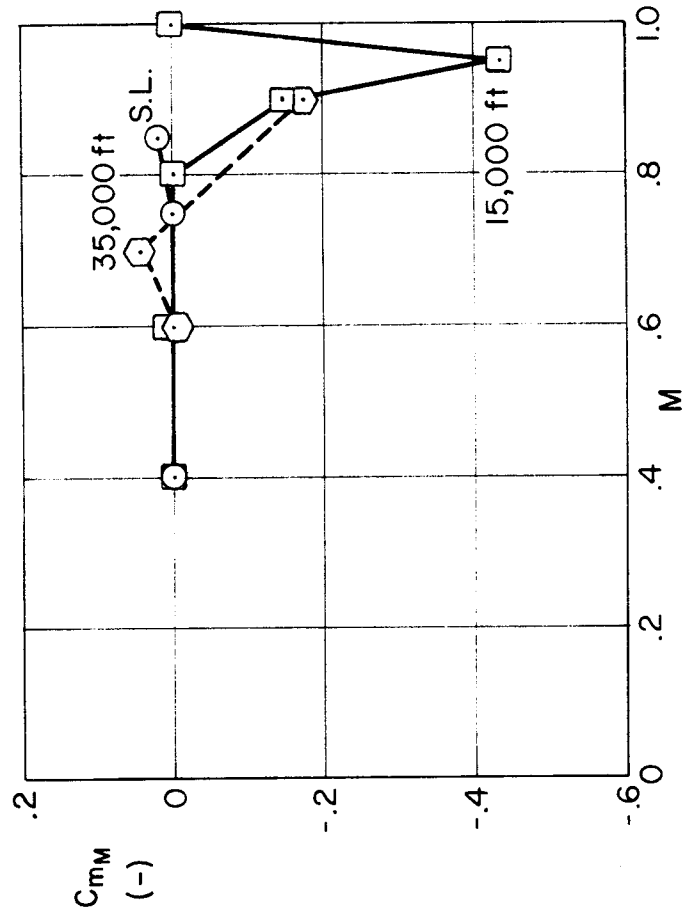
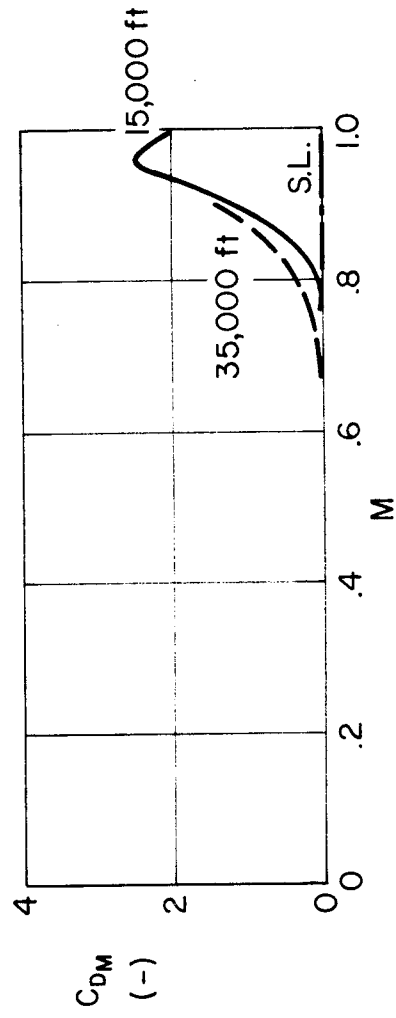
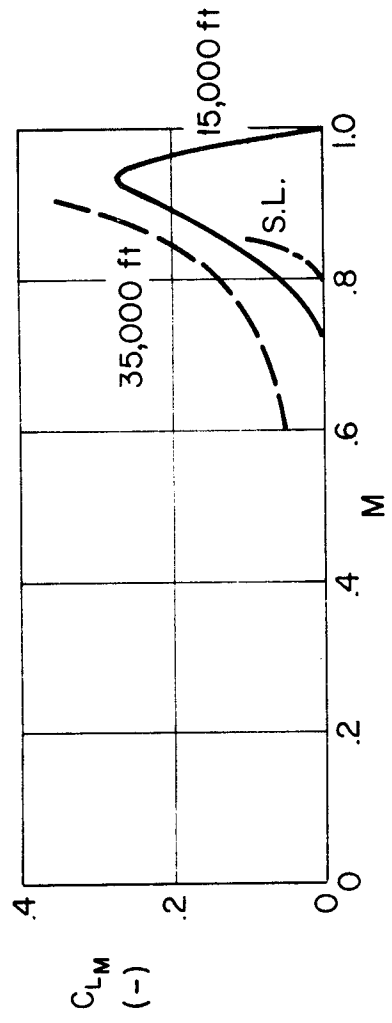


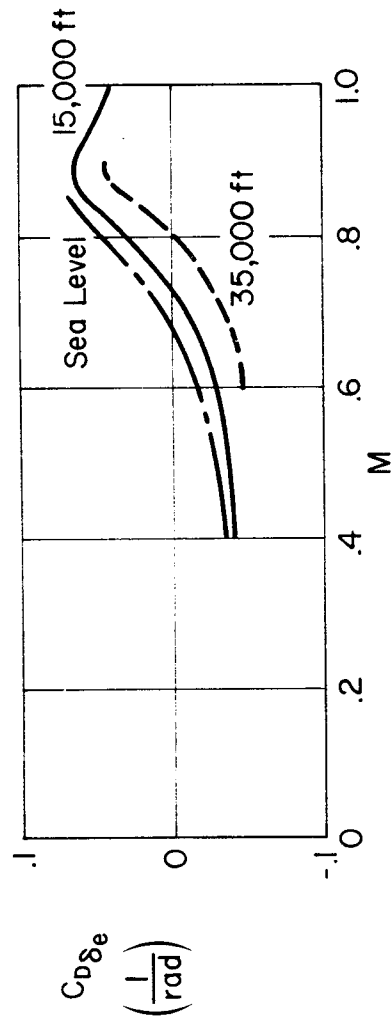
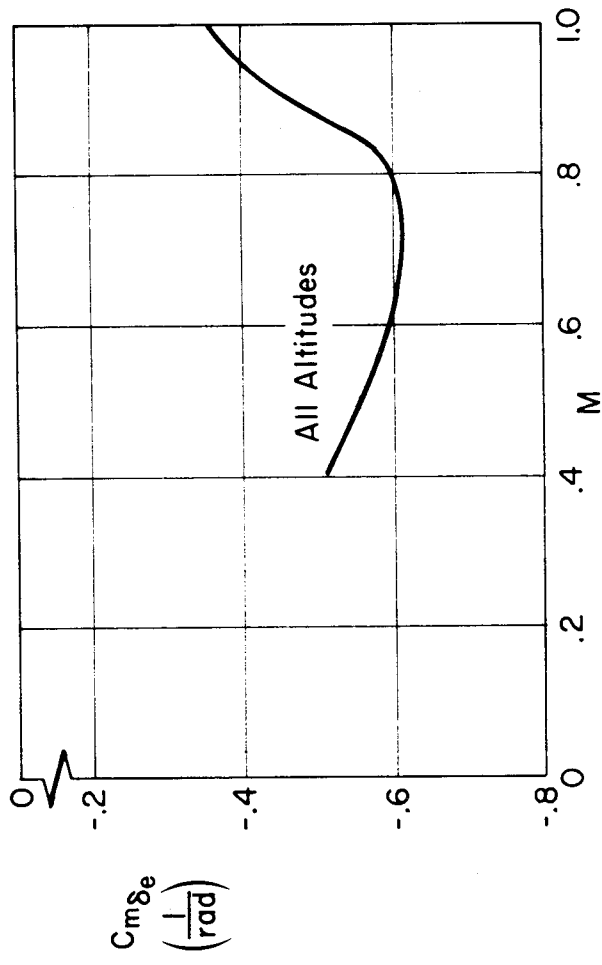
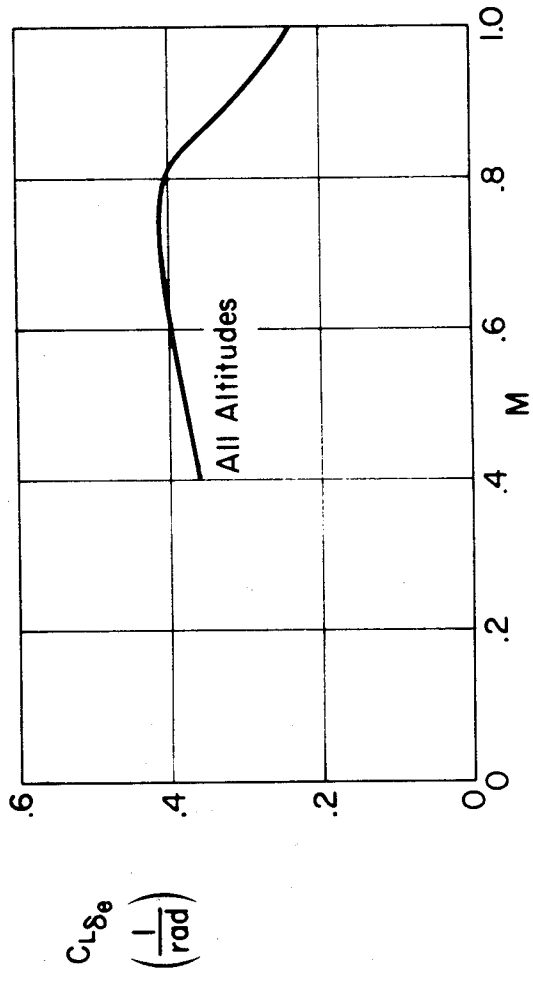


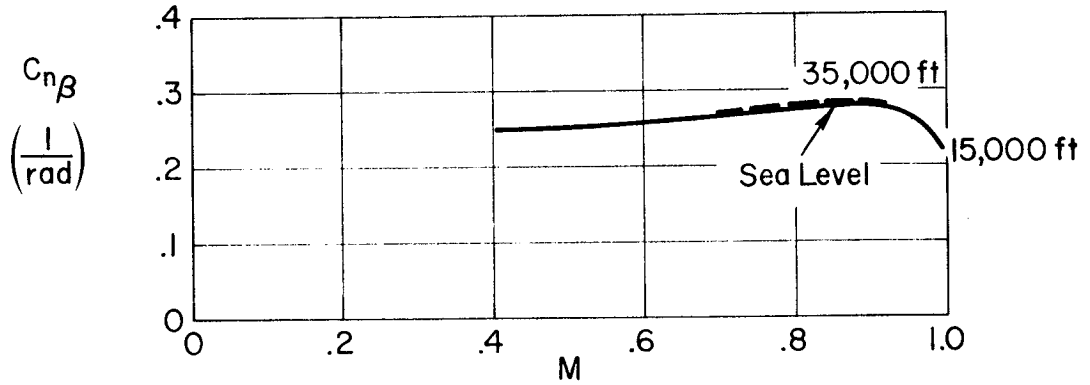
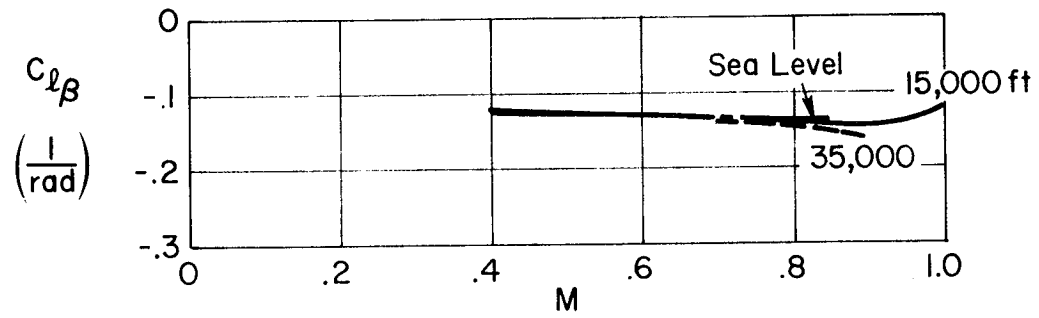
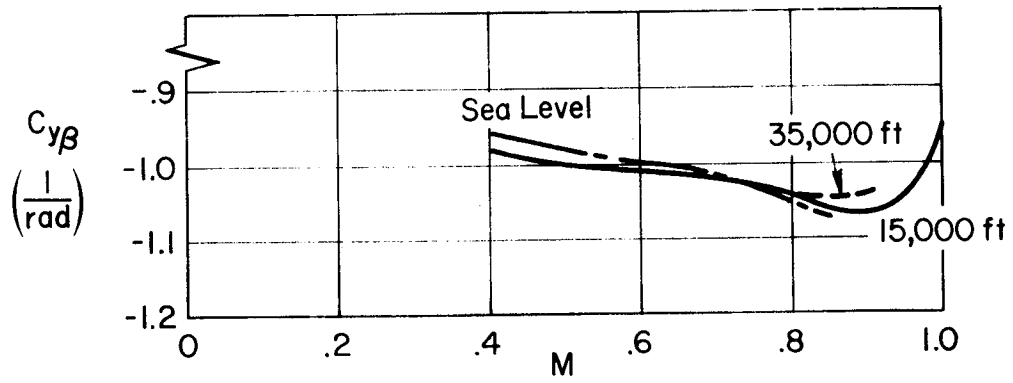


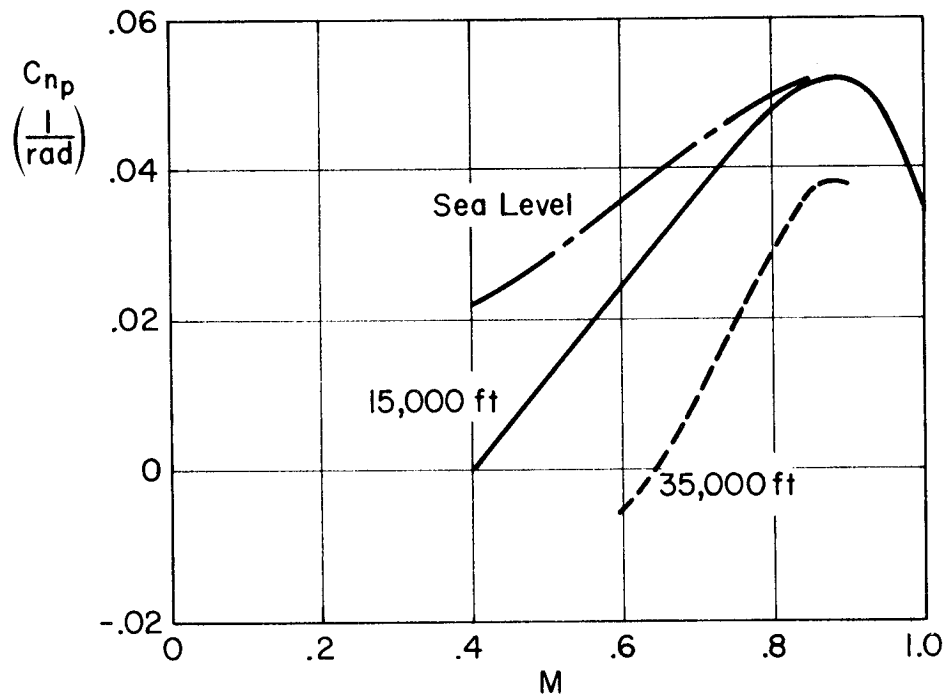
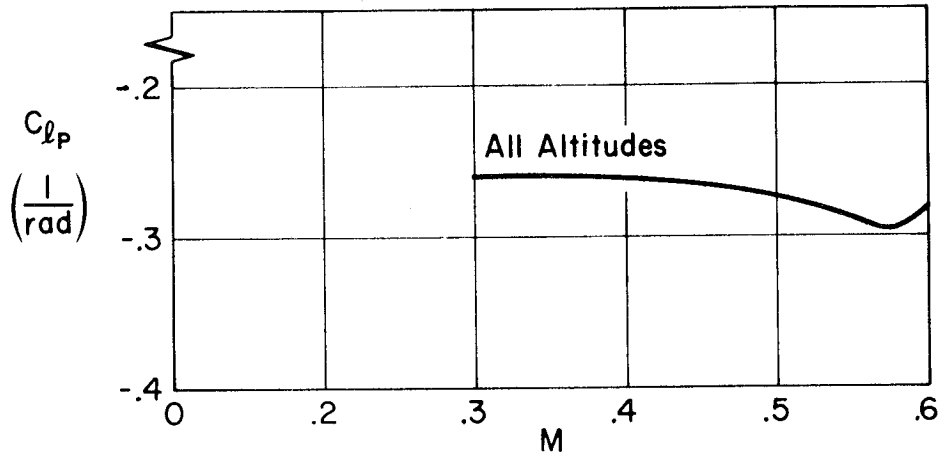


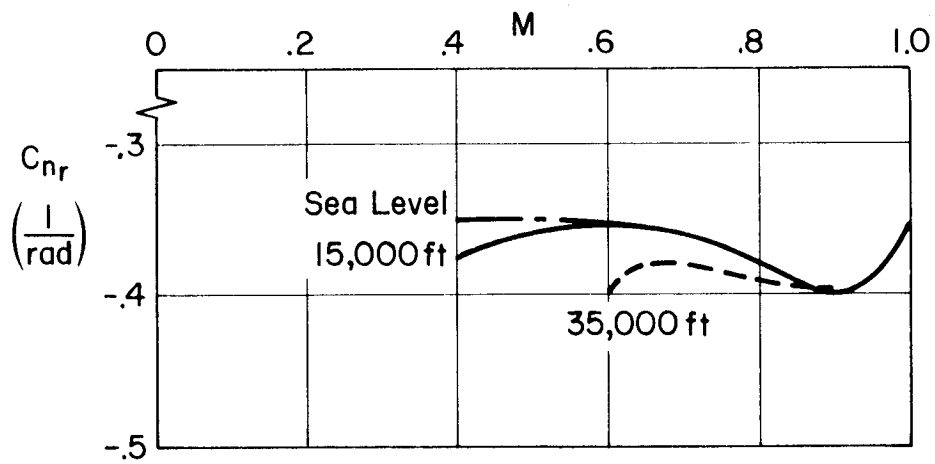
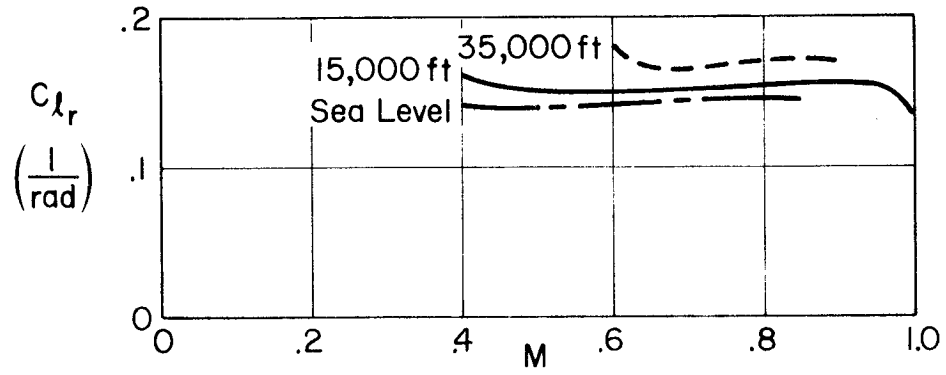


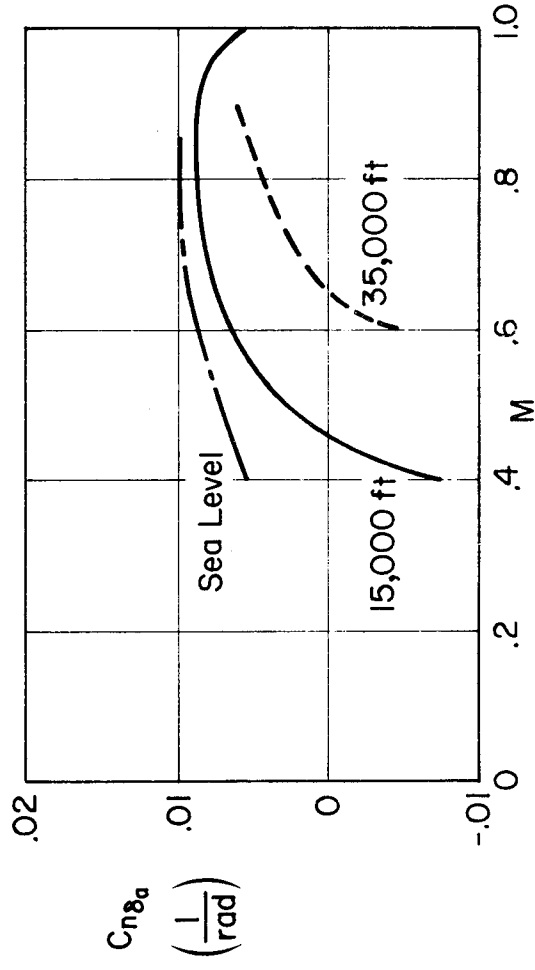
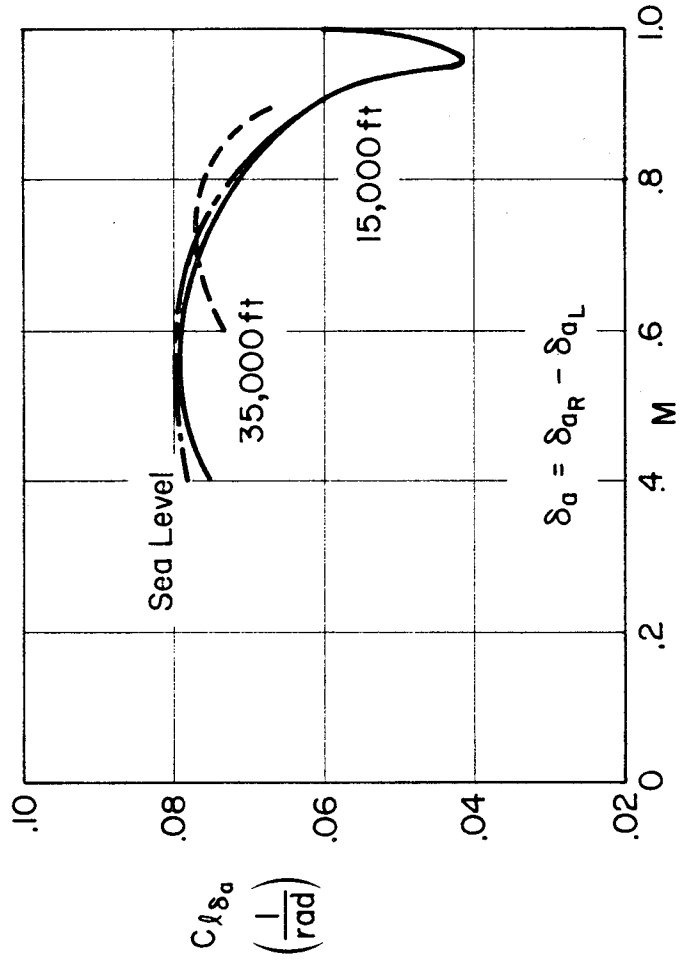
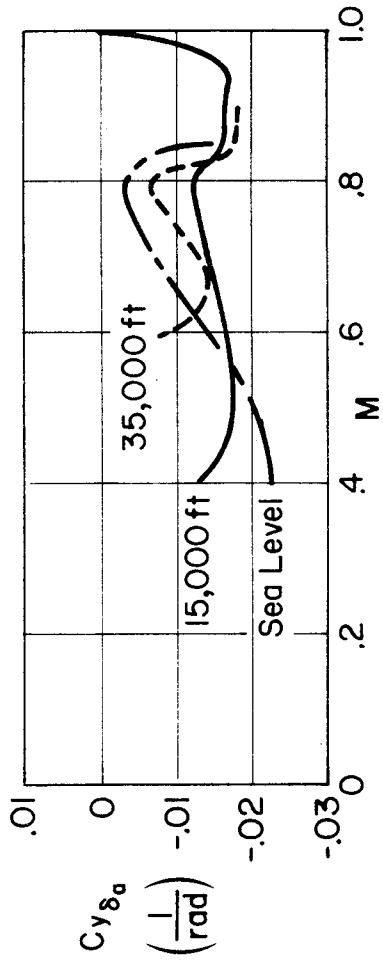












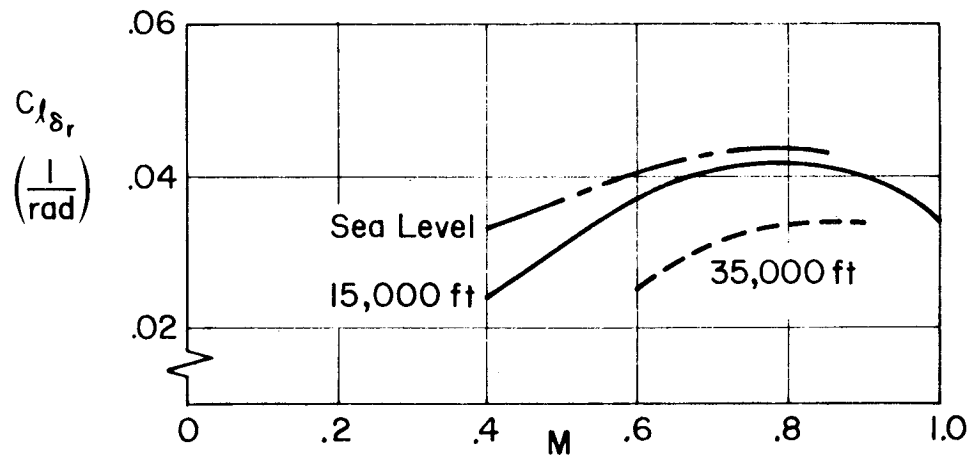
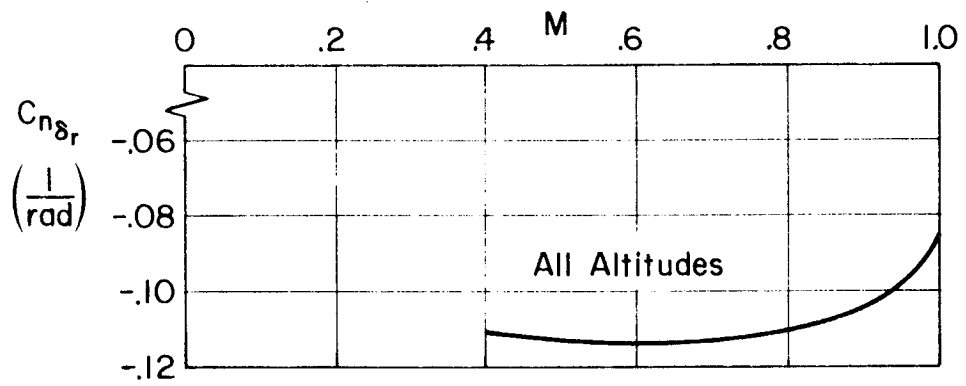
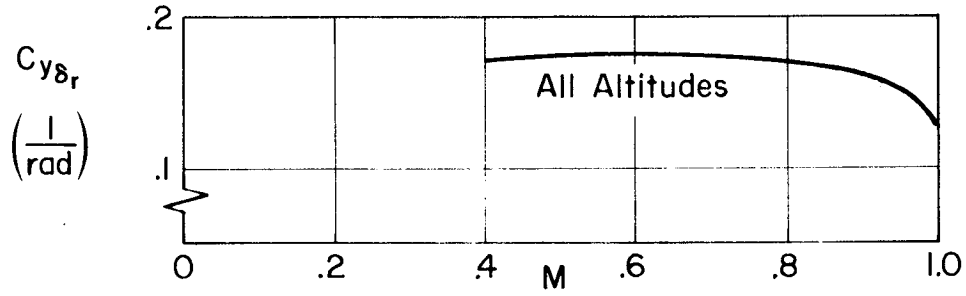


TABLE III-B

LONGITUDINAL DIMENSIONAL DERIVATIVES FOR THE A-4D

Note: Data are for body-fixed centerline axes, clean flexible airplane.

	FLIGHT CONDITION							
	1	2	3	4	5	6	7	8
h	0	0	15,000	15,000	15,000	15,000	35,000	35,000
M	0.4	0.85	0.4	0.6	0.9	1.0	0.6	0.9
X_w	0.0687	-0.0215	0.052	0.0422	-0.0303	-0.0251	0.0227	-0.0212
X_u	-0.00934	-0.0298	0.000877	-0.00938	-0.0615	-0.1343	0.000806	-0.0282
X_{δ_e}	7.612	-33.944	6.068	7.396	-19.723	-15.289	6.288	-3.873
Z_w	-0.899	-2.23	-0.535	-0.822	-1.478	-1.892	-0.3874	-0.677
Z_u	-0.0765	-0.0982	-0.0704	-0.0533	-0.1174	-0.0487	-0.0525	-0.0869
Z_{δ_e}	-42.08	-188.28	-22.273	-56.68	-103.23	-94.606	-23.037	-43.149
M_w	-0.0228	-0.0502	-0.0131	-0.0204	-0.0379	-0.1072	-0.00908	-0.01735
M_u	-0.000763	-0.00131	-0.000476	-0.000555	-0.000902	-0.000683	-0.000270	-0.000443
M_q	-1.151	-2.936	-0.670	-1.071	-1.934	-2.455	-0.484	-0.876
$M_{\dot{u}}$	0.00232	0.00340	0.00253	0.00162	-0.00906	0.00263	0.001824	-0.00412
M_{δ_e}	-13.728	-63.987	-7.400	-19.456	-33.809	-31.773	-8.096	-14.084

TABLE III-C

LATERAL DIMENSIONAL DERIVATIVES FOR THE A-4D

Note: Data are for body-fixed centerline axes, clean flexible airplane.

	FLIGHT CONDITION							
	1	2	3	4	5	6	7	8
h	0	0	15,000	15,000	15,000	15,000	35,000	35,000
M	0.4	0.85	0.4	0.6	0.9	1.0	0.6	0.9
Y_v	-0.2484	-0.5755	-0.1476	-0.228	-0.3628	-0.358	-0.1034	-0.1596
$Y_{\delta_a}^*$	-0.00582	-0.00807	-0.00188	-0.0038	-0.00556	0.00207	-0.000819	-0.002763
$Y_{\delta_r}^*$	0.044	0.0898	0.02561	0.03958	0.0549	0.049	0.01791	0.02487
L_p'	-29.71	-118.1	-17.52	-35.95	-82.086	-82.02	-17.557	-40.7
L_p'	-1.813	-3.844	-1.111	-1.566	-2.503	-2.708	-0.761	-1.167
L_r'	0.8731	1.776	0.613	0.812	1.208	1.113	0.475	0.6227
L_{δ_a}'	17.2	64.359	8.99	21.203	39.282	44.89	8.1704	16.85
L_{δ_r}'	8.217	37.214	4.309	10.398	22.103	22.943	4.1675	8.717
N_p'	13.203	67.279	6.706	16.629	42.527	39.85	6.352	17.31
N_p'	-0.029	0.02953	-0.0348	-0.02173	0.01647	-0.0260	-0.02513	-0.00539
N_r'	-0.5761	-1.4	-0.3432	-0.5144	-0.899	-0.88	-0.2468	-0.3893
N_{δ_a}'	1.4875	5.484	0.538	1.769	17.43	3.212	0.5703	1.399
N_{δ_r}'	-6.1953	-26.642	-3.280	-7.78	-16.36	-16.562	-3.16	-6.744

TABLE III-D

ELEVATOR LONGITUDINAL TRANSFER FUNCTION FACTORS FOR THE A-4D

Note: Data are for body-fixed centerline axes, clean flexible airplane.

		FLIGHT CONDITION							
		1	2	3	4	5	6	7	8
h		0	0	15,000	15,000	15,000	15,000	35,000	35,000
M		0.4	0.85	0.4	0.6	0.9	1.0	0.6	0.9
Δ	ζ_{sp}	0.352	0.435	0.2838	0.301	0.3435	0.233	0.214	0.2478
	ω_{sp}	3.39	7.348	2.445	3.718	6.232	10.857	2.358	3.951
	$\zeta_p(1/T_{p1})$	0.0735	0.195	0.682	0.086	(-0.06835)	(0.02574)	0.0859	(-0.050)
	$\omega_p(1/T_{p2})$	0.1035	0.08615	0.1105	0.0747	(0.1101)	(0.1019)	0.0822	(0.0563)
$N_{\delta_e}^\theta$	A_θ	-13.726	-63.98	-7.4	-19.456	-33.805	-33.771	-8.096	-14.083
	$1/T_{\theta1}$	0.0141	0.0319	0.00353	0.0112	0.0526	0.1284	-0.000615	0.02184
	$1/T_{\theta2}$	0.8234	2.079	0.489	0.76	1.362	1.572	0.3591	0.6259
$N_{\delta_e}^u$	A_u	7.628	-34.074	6.076	7.408	-19.776	-15.32	6.293	-3.878
	$1/T_{u1}$	66.931	-12.608	80.193	99.8	-20.49	-13.172	115.28	-160.9
	$\zeta_u(1/T_{u2})$	0.584	(2.615)	0.725	0.638	(0.98)	0.49	0.8554	(0.3383)
	$\omega_u(1/T_{u3})$	0.8481	(3.813)	0.4926	0.8042	(3.733)	2.824	0.3595	(1.337)
$N_{\delta_e}^w$	A_w	-42.08	-188.28	-22.274	-56.68	-103.23	-94.606	-23.034	-43.149
	$1/T_{w1}$	149.77	325.77	139.54	218.67	313.69	357.77	203.34	286.42
	$\zeta_w(1/T_{w2})$	0.0614	0.2653	-0.0172	0.0835	0.4915	(0.01471)	-0.0238	0.249
	$\omega_w(1/T_{w3})$	0.0761	0.0602	0.0771	0.0538	0.0546	(0.1127)	0.0565	0.0516
$N_{\delta_e}^h$	A_h	42.565	188.04	22.946	57.02	102.98	94.496	23.728	42.898
	$1/T_{h1}$	0.00122	0.0299	-0.0208	0.00436	0.050	0.1270	-0.01842	0.01593
	$1/T_{h2}$	11.623	27.426	8.454	13.376	21.62	24.916	8.5806	13.782
	$1/T_{h3}$	-10.415	-24.502	-7.712	-12.282	-19.671	-22.453	-8.048	-12.892
$N_{\delta_e}^{az}$	A_{az}	-42.08	-188.28	-22.274	-56.68	-103.23	-94.606	-23.037	-43.149
	$1/T_{az1}$	-0.0085	-0.00025	-0.0228	-0.00404	-0.000431	-0.000214	-0.0181	-0.00227
	$1/T_{az2}$	0.00962	0.0301	0.00187	0.00835	0.05043	0.127	-0.000296	0.01805
	$1/T_{az3}$	11.668	27.412	8.56	13.405	21.597	24.903	8.7174	13.762
	$1/T_{az4}$	-10.471	-24.484	-7.84	-12.321	-19.645	-22.437	-8.203	-12.868

TABLE III-E

AILERON LATERAL TRANSFER FUNCTION FACTORS FOR THE A-4D

Note: Data for body-fixed centerline axes, clean flexible airplane.

		FLIGHT CONDITION							
		1	2	3	4	5	6	7	8
h		0	0	15,000	15,000	15,000	15,000	35,000	35,000
M		0.4	0.85	0.4	0.6	0.9	1.0	0.6	0.9
Δ	$1/T_B$	0.00914	0.00568	0.00508	0.00595	0.00658	0.00726	0.00432	0.0067
	$1/T_R$	1.744	3.81	1.0152	1.5346	2.48	2.772	0.7013	1.137
	ζ_d	0.112	0.1207	0.0949	0.0885	0.0966	0.09123	0.0676	0.065
	ω_d	3.955	8.293	3.058	4.342	6.618	6.392	2.996	4.403
$N_{\delta a}^p$	A_p	17.199	64.36	8.988	21.203	39.282	44.89	8.17	16.85
	$1/T_{p1}$	-0.00572	-0.000233	-0.01182	-0.003	-0.00041	-0.000211	-0.0085	-0.00185
	ζ_p	0.1149	0.121	0.0977	0.0923	0.1015	0.0968	0.0717	0.0669
	ω_p	3.986	8.845	2.779	4.442	8.914	6.787	2.742	4.553
$N_{\delta a}^q$	A_φ	17.321	64.398	9.073	21.308	39.495	44.91	8.259	16.921
	ζ_φ	0.1149	0.121	0.0951	0.0924	0.1021	0.0968	0.070	0.067
	ω_φ	3.985	8.843	2.798	4.439	8.891	6.785	2.76	4.55
$N_{\delta a}^r$	A_r	1.4875	5.484	0.5376	1.769	17.427	3.212	0.5703	1.39
	$1/T_r$	0.9025	4.364	0.4868	0.873	2.601	3.054	0.3565	0.739
	ζ_r	0.1024	0.0571	0.0185	0.0847	0.0946	-0.0646	0.017	0.0695
	ω_r	3.767	2.655	4.475	3.694	1.521	2.523	4.073	3.519
$N_{\delta a}^b$	A_β	-0.00582	-0.00807	-0.001883	-0.0038	-0.00556	0.00207	-0.000819	-0.00276
	$1/T_{\beta 1}(\zeta_\beta)$	-2.178	-0.1615	(0.9834)	-0.723	-0.0447	-0.2036	(0.974)	-0.369
	$1/T_{\beta 2}(\omega_\beta)$	3.287	4.156	(0.5504)	1.704	2.537	2.2264	(0.4294)	1.368
	$1/T_{\beta 3}$	19.185	625.29	-456	134.95	3048.0	-1396.8	-838.16	197.67
$N_{\delta a}^{ay}$ CG	A_{ay}	-2.66	-7.665	-0.7967	-2.413	-5.294	2.193	-0.4781	-2.42
	$1/T_{ay 1}(\zeta_{ay 2})$	(0.7012)	-0.1975	0.3891	(-0.8875)	-0.0468	-0.1843	0.3626	-0.903
	$1/T_{ay 2}(\omega_{ay 2})$	(1.923)	4.248	0.6872	(2.2183)	2.54	2.266	0.4622	1.651
	$\zeta_{ay 3}(1/T_{ay 3})$	-0.0505	(-16.43)	0.0215	(1.869)	(-32.14)	0.0324	0.00935	(-2.903)
	$\omega_{ay 4}(1/T_{ay 4})$	3.049	(17.628)	8.743	(4.149)	(33.046)	23.254	9.772	(3.712)

TABLE III-F

RUDDER LATERAL TRANSFER FUNCTION FACTORS FOR THE A-4D

Note: Data for body-fixed centerline axes, clean flexible airplane.

		FLIGHT CONDITION							
		1	2	3	4	5	6	7	8
h		0	0	15,000	15,000	15,000	15,000	35,000	35,000
M		0.4	0.85	0.4	0.6	0.9	1.0	0.6	0.9
Δ	$1/T_S$	0.00914	0.00568	0.00508	0.00595	0.00658	0.00726	0.00432	0.0067
	$1/T_R$	1.744	3.81	1.0152	1.5346	2.48	2.772	0.7013	1.137
	ζ_d	0.112	0.1207	0.0949	0.0885	0.0966	0.09123	0.0676	0.065
	ω_d	3.955	8.293	3.058	4.342	6.618	6.392	2.996	4.403
$N_{\delta r}^p$	A_p	8.217	37.214	4.309	10.398	22.103	22.944	4.167	8.717
	$1/T_{p1}$	-0.00576	-0.000236	-0.0119	-0.003	-0.000412	-0.000212	-0.00851	-0.00186
	$1/T_{p2}$	3.0425	4.375	2.532	3.208	4.359	4.534	2.587	3.743
	$1/T_{p3}$	-3.029	-3.957	-2.6	-3.207	-4.196	-4.275	-2.664	-3.79
$N_{\delta r}^{\phi}$	A_{ϕ}	7.708	37.028	3.795	9.936	21.9	22.83	3.678	8.375
	$1/T_{\phi 1}$	3.086	4.376	2.642	3.248	4.378	4.539	2.725	3.797
	$1/T_{\phi 2}$	-3.211	-3.98	-2.902	-3.33	-4.227	-4.293	-2.936	-3.90
$N_{\delta r}^r$	A_r	-6.195	-26.642	-3.28	-7.78	-16.362	-16.562	-3.159	-6.744
	$1/T_r$	1.5484	3.815	0.615	1.348	2.495	2.786	0.393	0.930
	ζ_r	0.3075	0.363	0.308	0.272	0.1783	0.1828	0.207	0.20
	ω_r	0.7438	0.463	1.032	0.718	0.578	0.5411	1.128	0.850
$N_{\delta r}^{\beta}$	A_{β}	0.044	0.09	0.0256	0.0396	0.0549	0.049	0.0179	0.0249
	$1/T_{\beta 1}$	-0.00945	0.00133	-0.0209	-0.0067	-0.000324	0.000941	-0.0175	-0.00539
	$1/T_{\beta 2}$	1.7532	3.812	1.0312	1.537	2.485	2.76	0.711	1.145
	$1/T_{\beta 3}$	156.02	300.91	153.0	212.32	303.67	342.14	210.23	289.01
$N_{\delta r}^{a_y}$	A_{a_y}	20.1	85.33	10.835	25.134	52.296	51.83	10.459	21.784
	$1/T_{a_y 1}$	-0.0219	-0.00154	-0.039	-0.0147	-0.00486	-0.00224	-0.0326	-0.0141
	$1/T_{a_y 2}$	1.760	3.814	1.043	1.54	2.489	2.752	0.717	1.150
	$1/T_{a_y 3}$	5.14	10.957	3.864	5.73	8.618	9.465	3.733	5.385
CG	$1/T_{a_y 4}$	-4.49	-9.526	-3.415	-5.174	-7.7	-8.63	-3.411	-4.964

PRECEDING PAGE BLANK NOT FILMED.

SECTION IV

F-106B

Figure IV-1

F-106B

NOMINAL CRUISE CONFIGURATION

Clean Airplane

$W = 29,776$
 CG at 30.5% MGC
 $I_x = 18,634 \text{ slug-ft}^2$
 $I_y = 177,858 \text{ slug-ft}^2$
 $I_z = 191,236 \text{ slug-ft}^2$
 $I_{xz} = 5,539 \text{ slug-ft}^2$

} Body Ref.
 } Axes

REFERENCE GEOMETRY

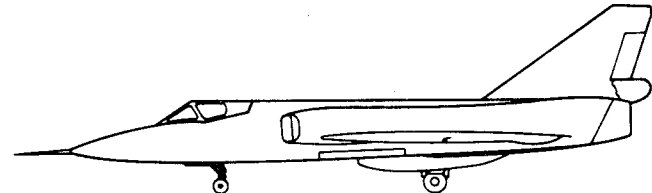
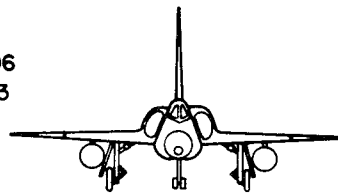
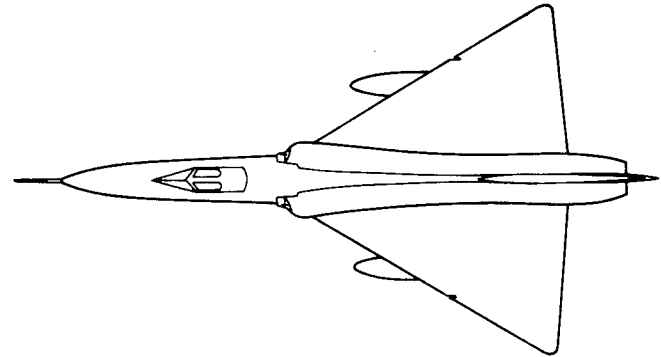
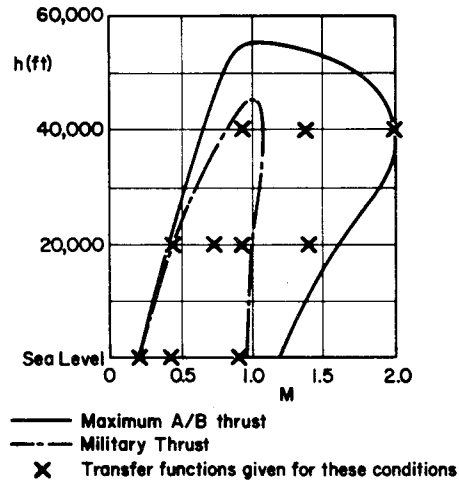
$S = 695 \text{ ft}^2$
 $c = 23.755 \text{ f}$
 $b = 38.13 \text{ ft}$

REFERENCES:

Weyel, A.E., A.H. Terp, C.A. Lunder, Description of F-106B Aircraft to Be Used as a Variable Stability Trainer, Service Engineering Div., Kelly AFB, Exhibit SANE-86, 9 Dec. 1963

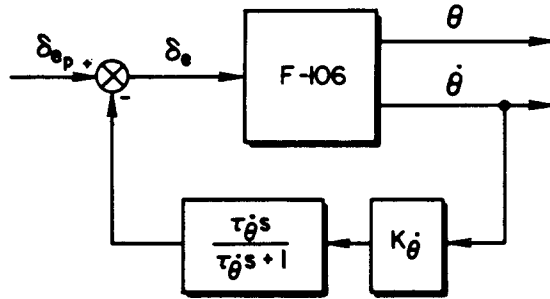
Collette, J.G.R., General Dynamics, Convair, A Compilation of F-106 Data From Various Convair Reports Contained in Letter, 14 May 1963

FLIGHT ENVELOPE

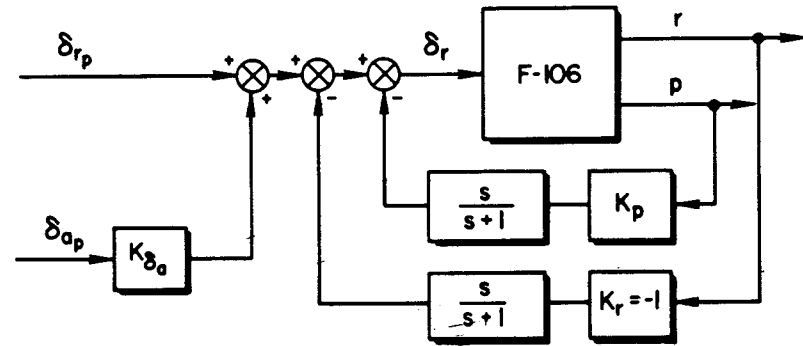


F-106

PITCH



YAW



SCHEDULED GAINS

SCHEDULED GAIN and TIME CONSTANTS

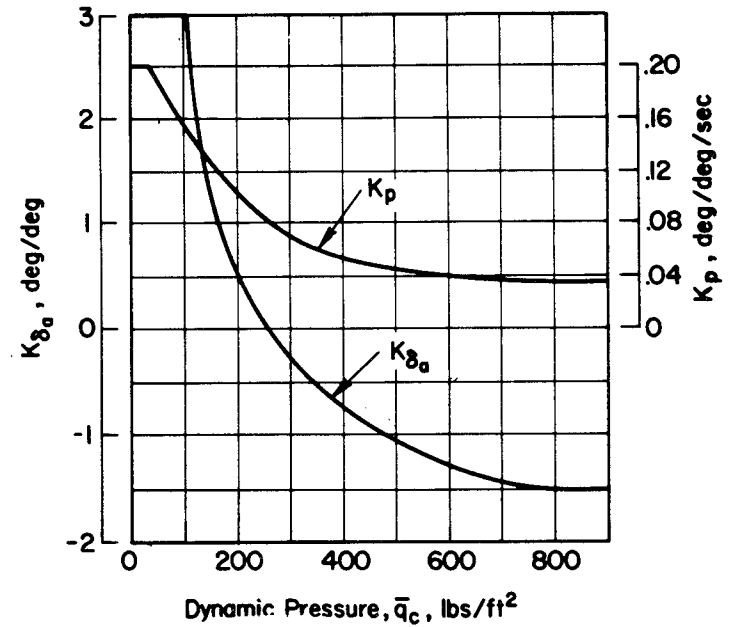
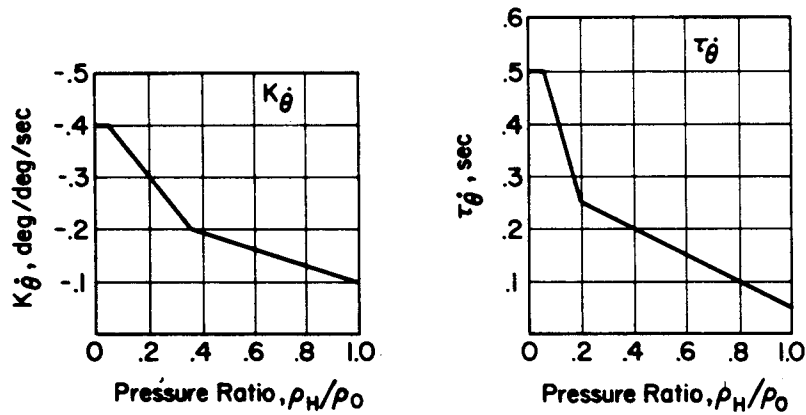


Figure IV-2. F-106 — Stability Augmentation System

TABLE IV-A
GEOMETRICAL PARAMETERS FOR THE F-106B

Note: Data are for body-fixed centerline axes

$b = 695$, $b = 38.13$, $c = 23.755$, cockpit location: $l_x = 17.5$, $l_z = -3.35$

	FLIGHT CONDITION											
	1	2*	3	4	5	6	7	8	9	10	11	12
h (ft)	20,000	20,000	20,000	S.L.	S.L.	20,000	S.L.	20,000	40,000	20,000	40,000	40,000
M (—)	0.755	0.755	0.755	0.2	0.4	0.4	0.9	0.9	0.9	1.4	1.4	2.0
a (ft/sec)	1,037	1,037	1,037	1,116	1,116	1,037	1,116	1,037	968	1,037	968	968
ρ (slugs/ft ³)	0.001267	0.001267	0.001267	0.002377	0.002377	0.001267	0.002377	0.001267	0.000587	0.001267	0.000587	0.000587
V_{To} (ft/sec)	785	785	785	223.2	446.4	414	1004.4	933	871	1,450	1,355	1,936
$\bar{q} = \rho V_{To}^2 / 2$ (lb/ft ²)	392	392	392	59.3	237.2	108.6	1,199	551	223	1,332	549	1,100
W (lb)	35,000	30,000	28,000	25,500	29,776	29,776	29,776	29,776	29,776	29,776	29,776	29,776
Mass (slugs)	1,090	931	870	791.9	924.7	924.7	924.7	924.7	924.7	924.7	924.7	924.7
I_x (slug-ft ²)	25,490	18,744	15,809	15,800	18,634	18,634	18,634	18,634	18,634	18,634	18,634	18,634
I_y (slug-ft ²)	195,156	185,300	177,645	160,783	177,858	177,858	177,858	177,858	177,858	177,858	177,858	177,858
I_z (slug-ft ²)	215,262	198,707	187,115	170,301	191,236	191,236	191,236	191,236	191,236	191,236	191,236	191,236
I_{xz} (slug-ft ²)	4947.1	5310.9	6015.4	5,727	5,539	5,539	5,539	5,539	5,539	5,539	5,539	5,539
x_{CG}/c	0.29	0.305	0.26	0.305	0.305	0.305	0.305	0.305	0.305	0.305	0.305	0.305
α_0 (deg)	4.42	4.04	3.88	18.0	4.9	11.0	2.0	2.7	5.4	1.2	2.70	1.2
γ_0 (deg)	0	0	0	0	0	0	0	0	0	0	0	0
θ_0 (deg)	4.42	4.04	3.88	18.0	4.9	11.0	2.0	2.7	5.4	1.2	2.7	1.2
U_0 (ft/sec)	784	784	784	212	445	406	1,004	933	868	1,450	1,355	1,936
W_0 (ft/sec)	60.6	55.4	53.1	73	40	80	36	44	82	30	64	40

*Optimum design condition

Note: Data are for body-fixed centerline axes
 Static aeroelastic corrections are included

TABLE IV-B
 LATERAL DIMENSIONAL DERIVATIVES FOR THE F-106B

FLIGHT CONDITION												
	1	2	3	4	5	6	7	8	9	10	11	12
\dot{h}	20,000	20,000	20,000	S.L.	S.L.	20,000	S.L.	20,000	40,000	20,000	40,000	40,000
M	0.755	0.755	0.755	0.2	0.4	0.4	0.9	0.9	0.9	1.4	1.4	2.0
Y^*	-0.207	-0.239	-0.259	-0.126	-0.237	-0.109	-0.277	-0.112	-0.423	-0.182	-0.217	-0.217
Y_{OE}^*	0.0799	0.0926	0.100	0.0492	0.0865	0.0443	0.108	0.0523	0.0470	0.0287	0.0128	0.0128
Y_{OI}^*	0.0347	0.0402	0.0435	0.0280	0.0438	0.0225	0.0392	0.0185	0.0235	0.00898	0.00940	0.00940
$I_{\dot{h}}^*$	-6.61	-8.78	-10.1	-20.0	-22.3	-19.2	-27.6	-18.9	-11.6	-55.1	-60.5	-60.5
$I_{\dot{p}}^*$	-1.69	-2.30	-2.74	-1.22	-2.35	-1.08	-5.14	-1.89	-4.25	-2.05	-2.69	-2.69
$I_{\dot{r}}^*$	1.22	1.64	1.91	3.51	2.86	2.12	4.56	1.60	2.63	1.36	2.65	2.65
I_{OI}^*	7.06	9.51	11.1	2.08	6.17	2.97	11.1	5.07	7.31	4.18	5.23	5.23
I_{OI}^*	-44.7	-61.1	-73.0	-13.3	-39.1	-19.5	-71.2	-34.7	-36.4	-26.2	-26.1	-26.1
$I_{\dot{p}}^*$	5.07	5.42	5.68	-0.192	2.17	0.506	7.50	2.79	18.9	7.78	11.1	11.1
$I_{\dot{r}}^*$	-0.0307	-0.0527	-0.0787	-0.0351	-0.0582	-0.0261	-0.0442	-0.0301	-0.113	-0.0512	-0.0684	-0.0684
$N_{\dot{p}}^*$	-0.472	-0.498	-0.513	-0.199	-0.472	-0.218	-0.627	-0.263	-0.823	-0.364	-0.376	-0.376
$N_{\dot{r}}^*$	-2.55	-2.68	-2.75	-0.505	-1.63	-0.792	-3.28	-1.44	-2.90	-1.45	-1.91	-1.91
N_{OI}^*	-5.09	-6.03	-7.01	-1.12	-3.51	-1.69	-9.34	-3.85	-7.54	-4.59	-5.64	-5.64

TABLE IV-D
 RUDDER LATERAL TRANSFER FUNCTION FACTORS FOR BASIC F-106B

		Flight Condition											
		1	2	3	4	5	6	7	8	9	10	11	12
Mach No., M Altitude, h C G Weight q, lb/ft ²		0.755 20,000 29 35,000 392	0.755 20,000 30.5 30,000 392	0.755 20,000 26 20,000 392	0.2 S.L. 30.5 25,500 59	0.4 S.L. 30.5 29,776 237	0.4 20,000 30.5 29,776 109	0.9 S.L. 30.5 29,776 1,199	0.9 20,000 30.5 29,776 551	0.9 20,000 30.5 29,776 223	1.4 20,000 30.5 29,776 1,332	1.4 40,000 30.5 29,776 549	2.0 40,000 30.5 29,776 1,100
Δ_{lat}	$1/T_s$	-0.0170	-0.0166	-0.0164	0.169	0.032	0.080	-0.004	-0.006	0.001	0.010	0.010	-0.003
	$1/T_R$	1.60	2.19	2.62	0.592	2.09	0.678	5.03	1.84	1.05	4.39	1.97	2.76
	ω_D	2.37	2.47	2.54	2.42	2.01	2.00	4.34	3.01	2.12	4.73	3.22	3.57
	ζ_D	0.164	0.175	0.178	0.162	0.233	0.162	0.224	0.159	0.129	0.116	0.095	0.074
p/δ_r	A_{pR}	7.06	9.51	11.1	2.08	6.17	2.97	19.5	11.1	5.07	7.31	4.18	5.23
	$1/T_{pR1}$	-0.00314	-0.00286	-0.00275	-0.043	-0.006	-0.015	-0.351	-0.782	-0.003	-0.0005	-0.001	-0.0003
	$1/T_{pR2}(\omega_{pR})$	(1.64)	(1.72)	(1.79)	1.88	1.85	1.97	-0.001	-0.002	1.54	5.13	3.35	3.10
	$1/T_{pR3}(\zeta_{pR})$	(0.0633)	(0.0701)	(0.0736)	-2.64	-2.05	-2.34	0.565	0.829	-1.69	-5.29	-3.40	-3.58
ϕ/δ_r	$A_{\phi R}$	6.86	9.32	10.9	1.92	6.03	2.81	19.3	11.0	4.94	7.25	4.11	5.19
	$1/T_{\phi R1}(\omega_{\phi R})$	(1.67)	(1.74)	(1.81)	-2.98	-2.12	-2.49	-0.406	-0.808	-1.74	-5.34	-3.45	-3.61
	$1/T_{\phi R2}(\zeta_{\phi R})$	(0.0468)	(0.0545)	(0.0582)	1.99	1.85	2.02	0.555	0.823	1.55	5.13	3.37	3.10
r/δ_r	A_{rR}	-2.55	-2.68	-2.75	-0.505	-1.63	-0.792	-6.16	-3.28	-1.44	-2.90	-1.45	-1.91
	$1/T_{rR1}$	-0.436	-0.431	-0.427	0.442	2.18	0.430	5.57	2.00	0.735	4.28	1.43	2.71
	$\omega_{rR}(1/T_{rR2})$	(0.349)	(0.365)	(0.375)	2.48	0.680	1.74	(0.383)	0.190	0.674	0.592	0.736	0.430
	$\zeta_{rR}(1/T_{rR3})$	(2.00)	(2.71)	(3.28)	0.214	0.415	0.243	(0.0062)	0.582	0.502	0.435	0.610	0.384
β/δ_r	$A_{\beta R}$	0.0347	0.0402	0.0435	0.028	0.0438	0.023	0.067	0.039	0.019	0.024	0.009	0.009
	$1/T_{\beta R1}$	-0.00111	-0.000727	-0.000530	-0.259	-0.033	-0.086	-0.004	-0.009	-0.021	-0.003	-0.004	-0.010
	$1/T_{\beta R2}$	1.56	2.11	2.53	0.690	2.07	0.780	5.08	1.85	1.07	4.36	1.98	2.74
	$1/T_{\beta R3}$	89.5	83.8	81.1	41.3	50.4	60.0	104	97.8	103	130	184	215
a_y/δ_r (CG)	A_{aR}	27.3	31.6	34.2	6.57	19.6	9.52	67.2	36.6	16.2	34.1	12.2	18.2
	$1/T_{aR1}(\omega_{aR})_1$	0.00614	0.00656	0.00679	(1.02)	-0.067	-0.333	-0.004	-0.010	-0.034	-0.012	-0.011	-0.012
	$1/T_{aR2}(\zeta_{aR})_1$	1.53	2.04	2.44	(0.986)	2.05	0.904	6.89	1.85	1.08	4.29	1.99	2.74
	$1/T_{aR3}(\omega_{aR})_2$	-3.30	-3.41	-3.49	(1.21)	-2.42	-1.16	-5.65	-3.92	-2.44	-5.37	-4.59	-5.65
$1/T_{aR4}(\zeta_{aR})_2$	3.92	4.16	4.29	-(0.243)	3.25	1.88	5.17	4.59	2.88	6.16	5.02	5.99	
a_y'/δ_r (cockpit)	A_{aR}'	6.40	16.6	23.3	4.71	11.8	5.60	24.9	16.5	8.03	7.89	0.784	2.32
	$1/T_{aR1}'$	0.0646	0.00670	0.00693	-0.300	-0.061	-0.135	-0.004	-0.010	-0.031	-0.012	-0.010	-0.012
	$1/T_{aR2}'$	-8.81	-6.05	-5.56	0.402	-6.36	0.428	-16.1	2.69	0.844	3.35	1.33	2.50
	$(\omega_{aR}')_1/T_{aR3}'$ $(\zeta_{aR}')_1/T_{aR4}'$	(3.05) (0.890)	(2.99) (0.730)	(3.08) (0.663)	-5.38 -3.26	(2.17) (0.949)	-5.47 3.55	(5.81) (0.703)	-8.13 3.39	-5.89 3.35	-21.5 8.69	-51.0 10.9	-34.4 8.54

TR-176-1

55

PRECEDING PAGE BLANK NOT FILMED.

SECTION V

T-38

1700
Preceding page blank

57

Figure V-1

T-38

NOMINAL CRUISE CONFIGURATION

Clean Airplane
 W = 9000 lbs
 CG at 23% MGC
 $I_x = 1438 \text{ slug-ft}^2$
 $I_y = 25,874 \text{ slug-ft}^2$
 $I_z = 26,779 \text{ slug-ft}^2$
 $I_{xz} = 0 \text{ (assumed)}$

} Body
 Ref.
 Axes

REFERENCE GEOMETRY

S = 170 ft²
 c = 7.73 ft
 b = 25.25 ft

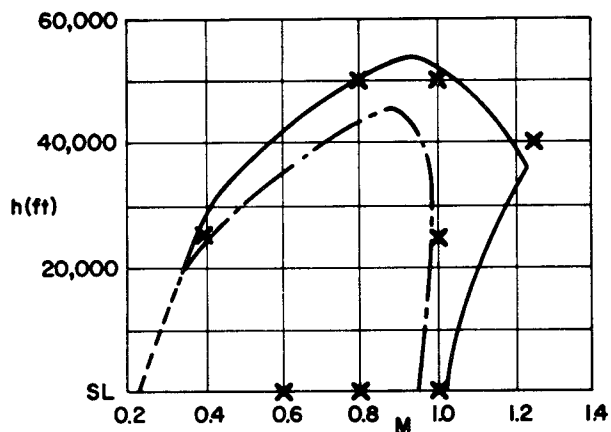
REFERENCES

- 1) T-38 Dynamic Stability, Norair Report NAI 58-704, April 1959

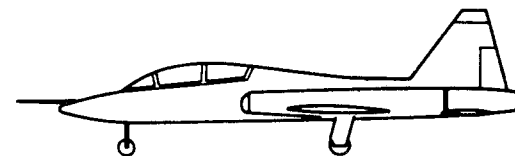
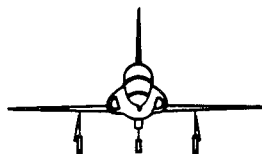
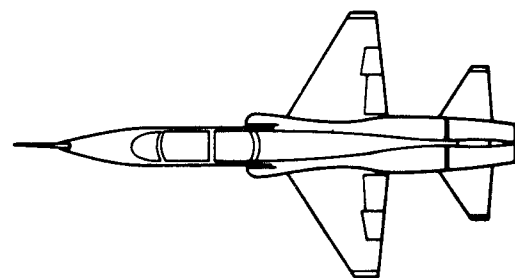
BASIC DATA SOURCES

Wind Tunnel Tests

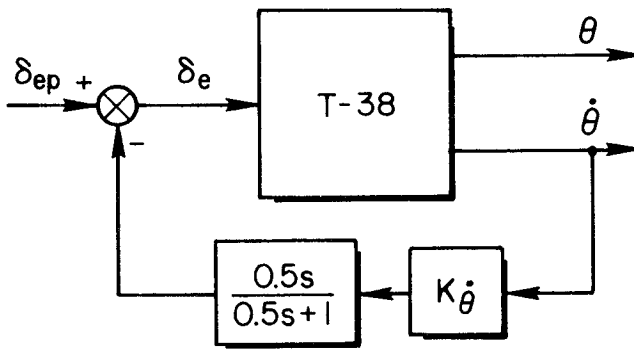
FLIGHT ENVELOPE



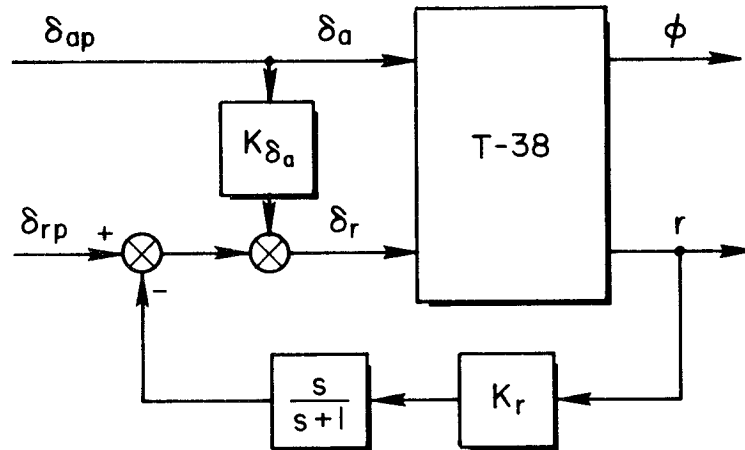
— Augmented Power
 - - - Military Power (J85-GE-5)
 X Lateral transfer functions given for these flight conditions



PITCH



YAW



SCHEDULED GAINS

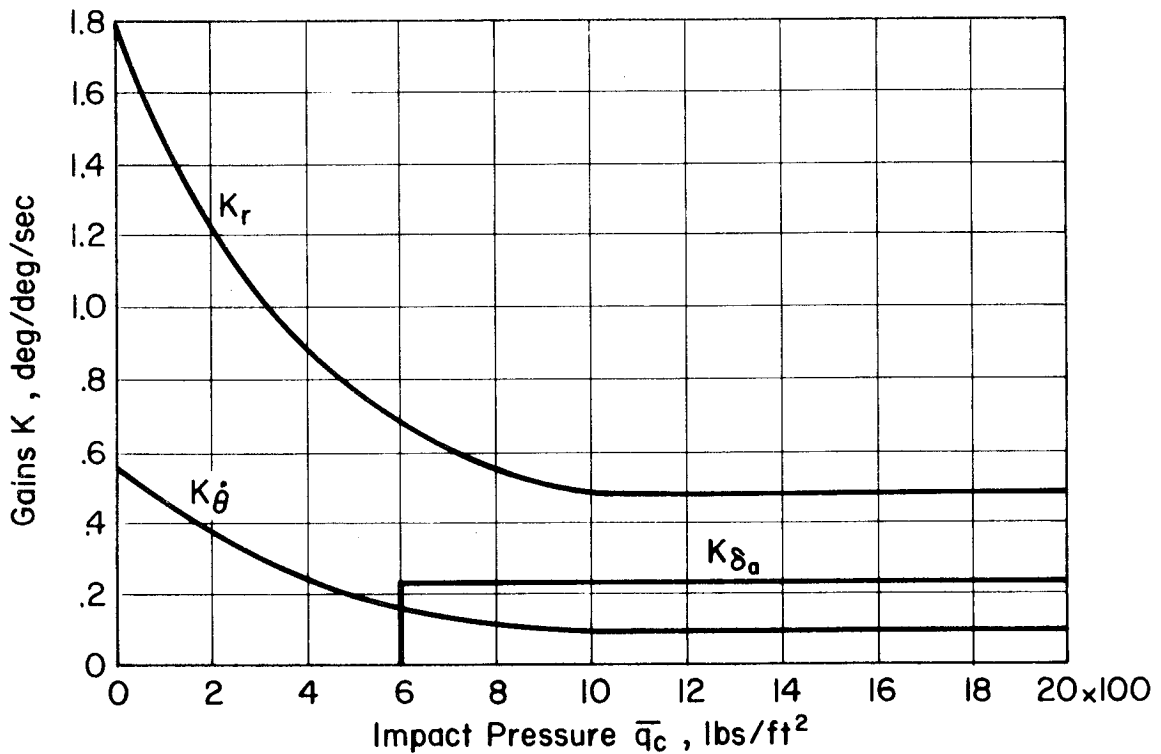


Figure V-2. T-38 — Stability Augmentation System

TABLE V-A

GEOMETRICAL PARAMETERS FOR THE T-38

Note: Data for body-fixed centerline axes, cruise configuration

$$s = 170 \text{ ft}^2, b = 25.25 \text{ ft}, c = 7.75 \text{ ft}$$

$$W = 10,000 \text{ lbs}, m = 511.0 \text{ slugs}, c.g. \text{ at } 23\% \text{ MAC}$$

$$I_x = 4,400 \text{ slug-ft}^2, I_y = 50,000 \text{ slug-ft}^2, I_z = 34,000 \text{ slug-ft}^2, I_{xz} = 0$$

FLIGHT CONDITION								
	1	2	3	4	5	6	7	8
h (ft)	0	0	0	25,000	25,000	50,000	50,000	40,000
M (-)	0.6	0.8	1.0	0.4	1.0	0.8	1.0	1.25
a (ft/sec)	1117	1117	1117	1016	1016	968.5	968.5	968.5
ρ (slug/ft ³)	0.002378	0.002378	0.002378	0.001065	0.001065	0.000367	0.000367	0.000585
V_{T0} (ft/sec)	670	893	1117	406	1016	774	968.5	1210
$\bar{q} = \rho V_{T0}^2 / 2$ (lb/ft ²)	535	950	1482	88	550	109	170	424
α_0 (deg)	1.1	0.8	0.6	8.7	1.5	5.0	3.1	1.2
γ_0 (deg)	0	0	0	0	0	0	0	0
U_0 (ft/sec)	669.8	892.8	1116.8	401.2	1015.7	771.3	965	1209.7
W_0 (ft/sec)	12.7	12.5	11.7	61.3	26.6	67.4	52.3	25.3

TABLE V-B

LATERAL NONDIMENSIONAL STABILITY DERIVATIVES FOR THE T-38

Note: Data are for body fixed centerline axes, cruise configuration

	FLIGHT CONDITION							
	1	2	3	4	5	6	7	8
h (ft)	0	0	0	25,000	25,000	50,000	50,000	40,000
M (-)	0.6	0.8	1.0	0.4	1.0	0.8	1.0	1.25
V_{T_0} (ft/sec)	670	893	1117	406	1017	774	968	1210
$C_{y\beta}$	-0.715	-1.27	-1.35	-1.26	-1.35	-1.26	-1.41	-1.20
$C_{y\delta_a}$	0	0	0	0	0	0	0	0
$C_{y\delta_r}$	0.155	0.172	0.103	0.160	0.132	0.183	0.126	0.097
$C_{l\beta}$	-0.057	-0.063	-0.085	-0.097	-0.086	-0.086	-0.080	-0.052
C_{l_p}	-0.320	-0.330	-0.275	-0.270	-0.365	-0.335	-0.390	-0.295
C_{l_r}	0.080	0.095	0.110	0.155	0.115	0.140	0.135	0.130
$C_{l\delta_a}$	0.037	0.030	0.0069	0.040	0.026	0.053	0.032	0.019
$C_{l\delta_r}$	0.016	0.018	0.012	0.017	0.015	0.021	0.016	0.0103
$C_{n\beta}$	0.262	0.315	0.332	0.240	0.335	0.286	0.340	0.310
C_{n_p}	0.076	0.078	0.084	0.085	0.078	0.052	0.070	0.076
C_{n_r}	-0.470	-0.435	-0.490	-0.340	-0.490	-0.380	-0.500	-0.53
$C_{n\delta_a}$	0.013	0.0143	0.0126	0.0069	0.0126	0.0149	0.0137	0.0149
$C_{n\delta_r}$	-0.092	-0.092	-0.063	-0.103	-0.086	-0.106	-0.086	-0.060

TR-176-1

61

TABLE V-C

LATERAL DIMENSIONAL DERIVATIVES FOR THE T-38

Note: Data are for body-fixed centerline axes, cruise configuration

	FLIGHT CONDITION							
	1	2	3	4	5	6	7	8
h (ft)	0	0	0	25,000	25,000	50,000	50,000	40,000
M (-)	0.6	0.8	1.0	0.4	1.0	0.8	1.0	1.25
Y_v	-0.311	-0.737	-0.98	-0.151	-0.4	-0.0982	-0.137	-0.232
$Y_{\delta_a}^*$	0	0	0	0	0	0	0	0
$Y_{\delta_r}^*$	0.0675	0.1	0.075	0.191	0.0391	0.0143	0.0122	0.0188
L'_β	-29.69	-58.29	-123.03	-8.491	-46.24	-9.293	-13.46	-21.73
L'_p	-3.14	-4.316	-4.5	-0.727	-2.435	-0.588	-0.8544	-1.286
L'_r	0.785	1.242	1.8	0.417	0.767	0.246	0.296	0.567
L'_{δ_a}	19.27	27.75	9.987	3.503	13.98	5.727	5.383	7.941
L'_{δ_r}	8.334	16.65	17.37	1.489	8.065	2.269	2.691	4.305
N'_β	17.65	37.71	62.18	2.72	23.31	4.0	7.402	16.77
N'_p	0.0965	0.132	0.178	0.296	0.0673	0.0118	0.0198	0.0429
N'_r	-0.597	-0.736	-1.037	-0.1185	-0.423	-0.086	-0.142	-0.30
N'_{δ_a}	0.876	1.712	2.36	0.0782	0.877	0.2084	0.298	0.806
N'_{δ_r}	-6.2	-11.01	-11.8	-1.167	-5.984	-1.482	-1.872	-3.245

TABLE V-D

AILERON LATERAL TRANSFER FUNCTION FACTORS FOR THE T-38

Note: Data for body-fixed centerline axes, cruise configuration

		FLIGHT CONDITION							
		1	2	3	4	5	6	7	8
h		0	0	0	25,000	25,000	50,000	50,000	40,000
M		0.6	0.8	1.0	0.4	1.0	0.8	1.0	1.25
Δ	$1/T_S$	0.0025	-0.0014	0.00141	-0.013	0.00016	-0.00594	-0.0031	-0.0043
	$1/T_R$	3.0197	4.145	4.185	0.605	2.275	0.548	0.803	1.236
	ζ_d	0.121	0.133	0.146	0.102	0.1	0.0527	0.0585	0.0705
	ω_d	4.251	6.2	7.97	1.98	4.94	2.187	2.847	4.151
$N_{\delta_a}^p$	A_p	19.273	27.75	10.0	3.50	13.98	5.727	5.383	7.941
	$1/T_{p1}$	-0.00091	-0.0005	-0.0003	-0.012	-0.00082	-0.00362	-0.0018	-0.000554
	ζ_p	0.108	0.12	0.127	0.0852	0.085	0.0473	0.052	0.0675
	ω_p	4.382	6.473	9.628	1.703	5.137	2.081	2.856	4.365
$N_{\delta_a}^\phi$	A_ϕ	19.29	27.78	10.01	3.515	14.0	5.745	5.4	7.96
	$1/T_{\phi 1}(\zeta_\phi)$	(0.108)	(0.12)	(0.127)	(0.0829)	(0.0853)	(0.047)	(0.0522)	(0.068)
	$1/T_{\phi 2}(\omega_\phi)$	(4.381)	(6.471)	(9.617)	(1.719)	(5.135)	(2.086)	(2.856)	(4.361)
$N_{\delta_a}^r$	A_r	0.876	1.712	2.36	0.782	0.877	0.2084	0.298	0.806
	$1/T_r$	4.439	5.405	4.80	0.535	1.52	0.484	0.638	1.401
	ζ_r	0.267	0.423	0.47	0.192	0.405	0.0827	0.129	0.143
	ω_r	2.127	2.113	1.523	4.345	2.95	3.19	2.765	1.884
$N_{\delta_a}^\beta$	A_β	-0.511	-1.323	-2.255	0.446	-0.511	0.289	-0.0074	-0.64
	$1/T_{\beta 1}(\zeta_\beta)$	-0.167	-0.0832	-0.0353	(0.706)	-0.0843	(0.58)	-0.21	-0.066
	$1/T_{\beta 2}(\omega_\beta)$	6.926	7.439	5.334	(0.287)	4.90	(0.283)	18.624	1.795
	$1/T_{\beta 3}$	—	—	—	—	—	—	—	—

TABLE V-E

RUDDER LATERAL TRANSFER FUNCTION FACTORS FOR THE T-38

Note: Data are for body-fixed centerline axes, cruise configuration.

		FLIGHT CONDITION							
		1	2	3	4	5	6	7	8
h		0	0	0	25,000	25,000	50,000	50,000	40,000
M		0.6	0.8	1.0	0.4	1.0	0.8	1.0	1.25
Δ	$1/T_s$	0.0025	-0.0014	0.00141	-0.013	0.00016	-0.00594	-0.0031	-0.0043
	$1/T_R$	3.0197	4.145	4.185	0.605	2.275	0.548	0.803	1.236
	ζ_d	0.121	0.133	0.146	0.102	0.1	0.527	0.585	0.0705
	ω_d	4.251	6.2	7.97	1.98	4.94	2.187	2.847	4.151
$N_{\delta r}^p$	A_p	8.33	16.65	17.37	1.49	8.065	2.27	2.691	4.305
	$1/T_{p1}$	-0.00092	-0.0005	-0.0003	-0.0119	-0.00082	-0.00361	-0.0018	-0.000583
	$1/T_{p2} (\zeta_p)$	-2.07	-0.797	-4.522	-2.06	-3.311	-1.454	-1.395	(0.0081)
	$1/T_{p3} (\omega_p)$	2.154	1.10	4.79	1.905	3.341	1.423	1.408	(0.605)
$N_{\delta r}^q$	A_q	8.215	16.5	17.245	1.31	7.91	2.14	2.59	4.237
	$1/T_{q1} (\zeta_q)$	-2.11	-0.827	-4.557	-2.293	-3.372	-1.526	-1.443	(-0.0103)
	$1/T_{q2} (\omega_q)$	2.15	1.09	4.79	1.994	3.350	1.451	1.42	(0.608)
$N_{\delta r}^r$	A_r	-6.2	-11.01	-11.8	-1.167	-5.984	-1.482	-1.872	-3.245
	$1/T_{r1}$	3.0	4.114	4.196	0.561	2.252	0.519	0.78	-0.0571
	$\zeta_r (1/T_{r2})$	0.206	(0.0302)	0.674	0.14	0.373	0.11	0.196	(0.193)
	$\omega_r (1/T_{r3})$	0.309	(0.367)	0.465	0.833	0.456	0.502	0.346	(1.23)
$N_{\delta r}^b$	A_b	0.067	0.0998	0.0748	0.0191	0.0391	0.0143	0.0122	0.188
	$1/T_{b1}$	-0.00063	-0.0016	-0.00212	-0.0372	-0.0034	-0.0107	-0.0052	-0.0041
	$1/T_{b2}$	2.994	4.075	4.205	0.655	2.302	0.558	0.810	1.23
	$1/T_{b3}$	94.93	113.63	161.56	72.21	159.0	117.48	164.64	178.02
$N_{\delta r}^{ay}$ CG	A_{ay}	45.24	89.16	83.53	7.852	39.77	11.08	11.88	22.72
	$1/T_{ay1}$	-0.0057	-0.0018	-0.00447	-0.0496	-0.00561	-0.014	-0.0063	-0.00398
	$1/T_{ay2}$	3.89	3.795	4.223	0.683	2.322	0.565	0.813	1.226
	$1/T_{ay3}$	-3.027	-6.248	-9.098	-2.525	-5.987	-2.536	-3.709	-4.732
	$1/T_{ay4}$	2.882	7.327	10.416	2.736	6.529	2.66	3.90	5.096

SECTION VI

F-5A

Figure VI-1

F-5A**CONFIGURATIONS**

GAR-8 - GAR-8 on wing tips

I - Centerline Tank

150 gal. tanks at W.S. 85

750 lb. stores at W.S. 114.5

50 gal. tip tanks

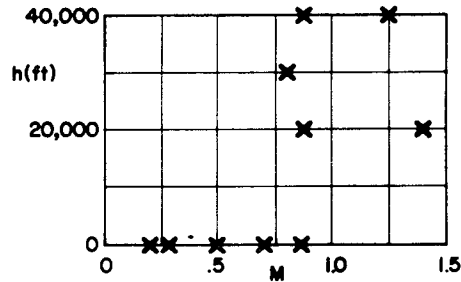
I-A - as I with 50% fuel

II - 2000 lb centerline store

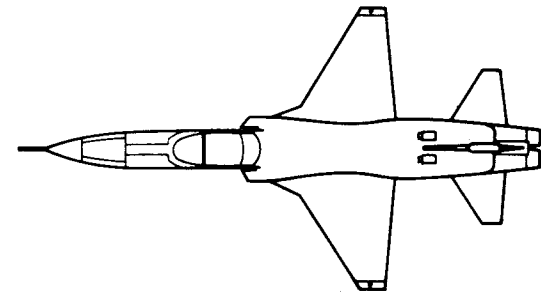
1000 lb stores at W.S. 85

750 lb stores at W.S. 114.5

50 gal. tip tanks



× Longitudinal data given at these flight conditions, see Table E.5a for configuration, \bar{n}_z , and γ_0

**REFERENCE GEOMETRY**S = 170 ft²

b = 25.25 ft

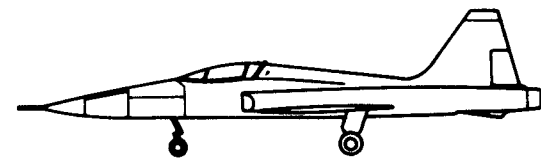
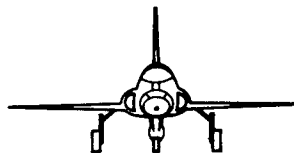
c = 7.75 ft

REFERENCE

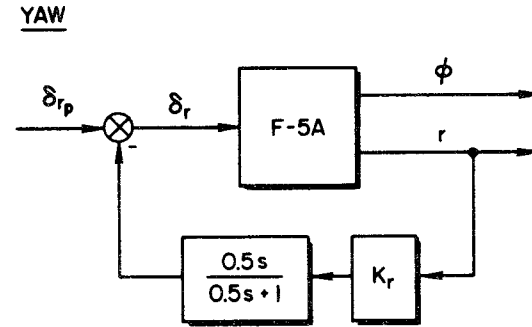
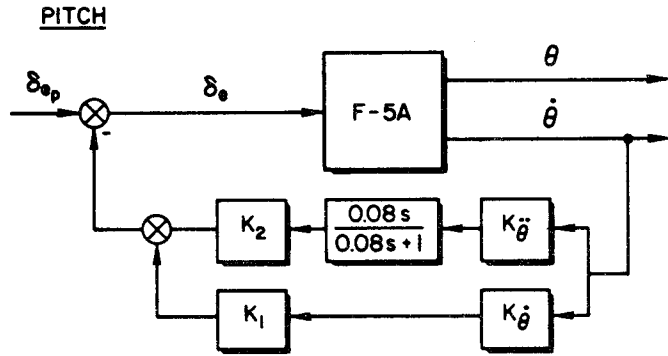
- 1) Jex, H.R. and J. Nakagawa, Typical F-5A Longitudinal Aerodynamic Data and Transfer Functions for 14 Conditions, Systems Technology, Inc., Technical Memorandum No. 239-4, March 1964

BASIC DATA SOURCES

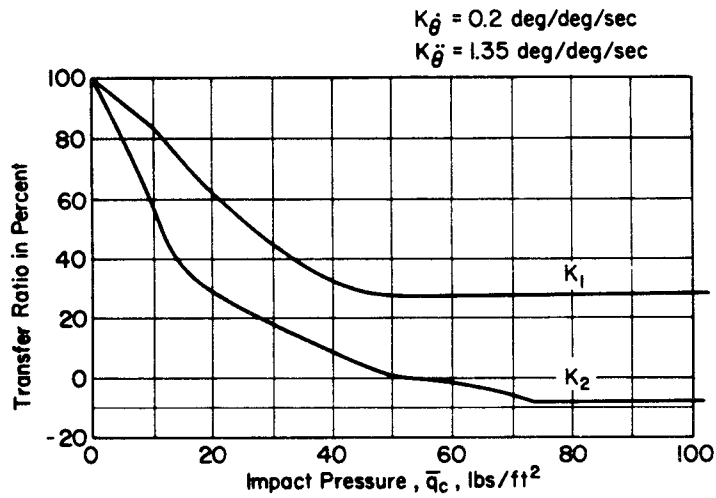
Wind tunnel tests with corrections made per flight test.



F-5A



SCHEDULED GAINS



SCHEDULED GAIN

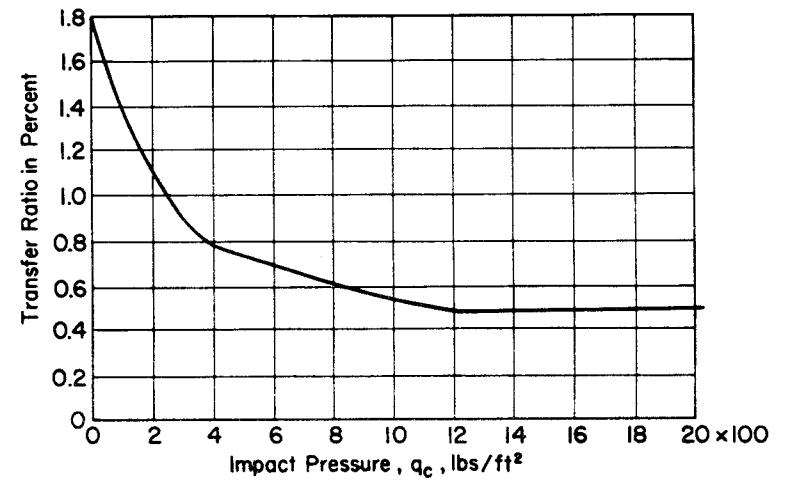


Figure VI-2. F-5A — Stability Augmentation System

TABLE VI-A
GEOMETRICAL PARAMETERS FOR THE F-5A

Note: $S = 170 \text{ ft}^2$, $b = 25.25 \text{ ft}$, $c = 7.73 \text{ ft}$, $t_o = 0.5 \text{ deg}$
Data are for body-fixed stability axes.

	FLIGHT CONDITION													
	1	2	3	4	5	6	7	8	9	10	11	12	13	14
Configurations	GAR-8	GAR-8	GAR-8	GAR-8 + Dive Brake	GAR-8 Flaps + Slats	I + Flaps	I	I-A + Dive Brake	MK 84 G + TT Empty	TT Empty	I-A	I-A	II 50% Fuel	II 50% Fuel
h (ft)	40,000	40,000	0	20,000	0	0	30,000	20,000	0	0	0	0	0	0
M	0.875	1.25	0.875	1.40	0.204	0.286	0.8	0.875	0.875	0.875	0.70	0.70	0.50	0.50
γ_o (deg)	0	0	0	-60	0	0	0	-60	0	0	0	0	0	0
$\bar{\Gamma}_x = L/W \cos \gamma_o$	1.0	1.0	1.0	0.5	1.0	1.0	1.0	0.5	1.0	4.0	1.0	4.0	1.0	2.0
α_o (deg)	3.2	1.0	0.8	0	12	12	9.0	2.8	1.2	2.8	2.8	7.0	4.4	8.0
V_{T_o} (ft/sec)	850	1210	980	1450	228	320	796	910	980	980	784	784	560	560
\bar{q} (lb/ft ²)	210	428	1130	1340	61.9	122	282	521	1,130	1,130	725	725	370	370
W (lbs)	10,000	10,000	10,000	10,000	10,000	19,000	17,000	14,000	14,000	12,000	14,000	14,000	17,000	17,000
$x_{c.g.}/c$	0.22	0.22	0.22	0.22	0.22	0.14	0.12	0.15	.03	0.17	0.15	0.15	0.13	0.13
m (slugs)	311	311	311	311	311	590	528	435	435	373	435	435	528	528
$\delta\alpha_o$ (deg)	-1.15	-1.80	-0.45	1.02	-4.28	-6.26	-2.57	0.52	-1.55	-2.62	-1.13	-4.62	-2.86	-5.77
I_y (slug-ft ²)	30,000	30,000	30,000	30,000	31,000	34,600	34,600	37,900	38,700	37,100	37,900	37,900	34,400	34,400
I_x (Pilot)	12.0	12.0	12.0	12.0	12.0	11.4	11.2	11.4	10.5	11.6	11.4	11.4	11.3	11.3

TABLE VI-C

LONGITUDINAL DIMENSIONAL DERIVATIVES FOR THE F-5A

Note: Data are for body-fixed stability axes, quasi-steady aeroelastic corrections included.

Configurations	FLIGHT CONDITION													
	1	2	3	4	5	6	7	8	9	10	11	12	13	14
	GAR-8	GAR-8	GAR-8	GAR-8 + Dive Brake	GAR-8 Flaps + Slats	I + Flaps	I	I-A + Dive Brake	MK 84 G, + TT Empty	TT Empty	I-A	I-A	II 50% Fuel	II 50% Fuel
h (ft)	40,000	40,000	0	20,000	0	0	30,000	20,000	0	0	0	0	0	0
M	0.875	1.25	.875	1.40	0.204	0.286	0.8	0.875	0.875	0.875	0.70	0.70	0.50	0.50
X _w (1/sec)	-0.00803	-0.0126	0.0101	0.0209	-0.0609	-0.0301	0.000338	0.0117	0.0222	0.0276	0.0178	0.0167	0.00128	0.0144
X _u [*] (1/sec)	-0.0109	-0.00589	-0.0452	-0.0505	0.0564	-0.0401	-0.0158	-0.0362	-0.0335	-0.0505	-0.0192	-0.0309	-0.0182	-0.0319
Z _w (1/sec)	-0.734	-1.05	-3.44	-2.22	-0.508	-0.431	-0.521	-1.10	-1.86	-2.23	-1.74	-1.61	-1.02	-0.828
Z _u [*] (1/sec)	-0.124	0.118	-0.289	0.401	-0.276	-0.197	-0.0575	-0.114	-0.0656	-0.0310	-0.0822	-0.327	-0.115	-0.229
Z _{δ_e} (ft/sec ² /rad)	-119	-175	-555	-439	-24.1	-26.9	-78.6	-181	-409	-475	-236	-235	-99.1	-97.7
M _w (1/sec-ft)	-0.00399	-0.0227	-0.0187	-0.0593	-0.00838	-0.0138	-0.00852	-0.00961	-0.0408	-0.0253	-0.0174	-0.0202	-0.0174	-0.0169
M _u [*] (1/ft)	-0.0000595	0.000149	-0.000141	0.000247	0	0	-0.0000327	-0.0000851	-0.000109	-0.000114	-0.0000159	-0.0000159	-0.0000176	-0.0000176
M _q (1/sec)	-0.429	-0.540	-1.92	-1.08	-0.296	-0.372	-0.488	-0.888	-1.48	-1.55	-0.973	-0.969	-0.667	-0.662
M _u [*] (1/sec-ft)	-0.000462	-0.00193	0.0000737	-0.000534	0.000142	0.000626	0.000325	-0.00499	-0.0103	0.00585	0.000166	0.000266	0.000327	0.000477
M _{δ_e} (1/sec ² /rad)	-14.3	-24.2	-73.1	-63.2	-3.16	-5.31	-14.5	-26.1	-59.8	-62.1	-31.3	-31.0	-17.0	-16.7

Note: The transfer functions given in Table E.5c) are based on the above derivatives and the equations of Appendix C with additional corrections made for Inertial Bending as follows:

$$(\omega_{sp}^2)_{IB} = \frac{(\omega_{sp}^2)_R + U_0 K_{a_z} (Z_6 M_w - Z_w M_6)}{1 - K_{a_z} Z_6}$$

$$(\text{First coefficient})_{IB} = \frac{1}{(1 - K_{a_z} Z_6)} \cdot (\text{first coefficient})_R \quad K_{a_z} = -0.000162 \text{ rad/ft/sec}^2$$

$$(\text{DC gain})_{IB} = \frac{(\omega_{sp}^2)_R}{(\omega_{sp}^2)_{IB}} \cdot \frac{1}{(1 - K_{a_z} Z_6)} \cdot (\text{DC gain})_R$$

where subscript IB = corrected value

R = rigid-body + quasi-steady
aeroelastic corrections

TABLE VI-D

LONGITUDINAL TRANSFER FUNCTIONS FOR THE F-5A

Note: Data are for body-fixed stability axes; corrections have been made for Inertial Bending

	FLIGHT CONDITION														
	1	2	3	4	5	6	7	8	9	10	11	12	13	14	
h (ft)	40,000	40,000	0	20,000	0	0	30,000	20,000	0	0	0	0	0	0	
M	0.875	1.25	0.875	1.40	0.204	0.286	0.8	0.875	0.875	0.875	0.70	0.70	0.50	0.50	
\bar{n}_z/γ_0 (deg)	1.0/0	1.0/0	1.0/0	0.5/-60	1.0/0	1.0/0	1.0/0	0.5/-60	1.0/0	4.0/0	1.0/0	4.0/0	1.0/0	2.0/0	
Wt.	10,000	10,000	10,000	10,000	10,000	19,000	17,000	14,000	14,000	12,000	14,000	14,000	17,000	17,000	
C.G.	0.22	0.22	0.22	0.22	0.22	0.14	0.12	0.15	0.03	0.17	0.15	0.15	0.13	0.13	
Δ	ω_{BP}	2.29	5.84	5.65	11.4	1.43	2.14	2.82	3.78	8.05	7.39	4.81	4.95	3.50	3.36
	ζ_{BP}	0.266	0.121	0.325	0.128	0.286	0.188	0.182	0.270	0.215	0.262	0.283	0.262	0.243	0.223
	ω_p (1/T _{p1})	0.0367	(-0.0721)	0.0856	(-0.0346)	0.197	0.147	0.0553	(-0.0530)	(-0.0964)	0.126	0.0601	0.115	0.0852	0.118
	ζ_p (1/T _{p2})	0.0761	(0.0750)	0.257	(0.104)	0.108	0.142	0.153	(0.116)	(0.128)	0.197	0.157	0.129	0.106	0.132
$N_{\delta e}^{\theta}$	$A_{\theta e}$	-14.6	-25.0	-80.4	-68.3	-3.16	-5.31	-14.6	-26.9	-64.0	-67.0	-32.6	-32.2	-17.3	-17.0
	1/T _{θe_1}	0.0955	0.00778	0.0461	0.0457	0.0170	0.0223	0.0159	0.0371	0.0334	0.0516	0.0202	0.0348	0.0184	0.0267
	1/T _{θe_2}	0.703	0.885	3.30	1.81	0.484	0.379	0.474	1.03	1.58	2.04	1.60	1.46	0.921	0.724
$N_{\delta e}^u$	A_{ue}	0.970	2.26	-6.15	-9.91	1.47	0.810	-0.0269	-2.19	-9.74	-14.1	-4.38	-4.06	-0.130	-1.44
	1/T _{ue_1}	0.580	0.602	4.72	-1.95	0.312	0.280	0.478	2.91	4.68	9.53	2.79	2.42	0.942	0.969
	1/T _{ue_2}	586	523	-294	100	98.6	273	-17,450	-68.6	-71.4	-32.6	-137	-154	-4210	-288
$N_{\delta e}^w$	A_{we}	-121	-180	-610	-474	-24.1	-26.9	-79.5	-186	-438	-513	-246	-244	-101	-99.7
	1/T _{$w e_1$}	103	168	131	210	29.5	62.1	146	131	145	129	105	104	96.3	95.6
	ω_{we} (1/T _{$w e_2$})	0.0673	(-0.0563)	0.0969	(-0.0338)	0.199	0.143	0.0492	0.0501	(-0.00410)	0.0496	0.0583	0.116	0.0820	0.116
	ζ_{we} (1/T _{$w e_3$})	0.0809	(0.0622)	0.233	(0.103)	0.139	0.139	0.161	0.666	(0.0376)	0.509	0.165	0.132	0.111	0.137
$N_{\delta e}^{\dot{h}}$	A_{he}	121	180	610	238	24.1	26.9	79.5	93.4	438	513	246	244	101	99.7
	1/T _{$h e_1$}	0.00309	0.0117	0.0432	0.0680	-0.0718	-0.337	0.0108	0.0661	0.0335	0.0503	0.0180	0.0253	0.0110	0.0180
	1/T _{$h e_2$}	-8.23	-12.0	-19.6	-18.8	-3.39	-4.50	-8.04	-11.0	-14.3	-15.3	-12.4	-11.9	-9.05	-7.98
	1/T _{$h e_3$}	8.72	12.4	21.7	19.6	3.81	4.95	8.56	12.0	15.9	17.0	13.4	12.8	9.73	8.67
$N_{\delta e}^{\dot{a}_z}$ (Pilot)	A_{ze}	54.0	120	353	346	13.8	33.6	84.8	119	233	264	125	124	94.6	93.2
	1/T _{$z e_1$} ($\omega_{z e_1}$)	0	0	0	0.0177	0	0	0	(0.0338)	0	0	0	0	0	0
	1/T _{$z e_2$} ($\zeta_{z e_1}$)	0.00309	0.0117	0.0432	0.0499	-0.0714	-0.0336	0.0108	(0.984)	0.0335	0.0503	0.0180	0.0254	0.0110	0.0180
	$\omega_{z e}$ $\zeta_{z e}$	12.8	15.0	27.1	22.7	4.76	4.23	8.03	14.5	20.6	22.5	18.1	17.2	9.70	8.60
		0.0476	0.0559	0.101	0.0720	0.0871	0.0505	0.0276	0.0381	0.0379	0.0618	0.0781	0.0699	0.0613	0.0468

TR-176-1

71

PRECEDING PAGE BLANK NOT F

SECTION VII

F-104

Preceding page blank

Figure VII-1

F-104

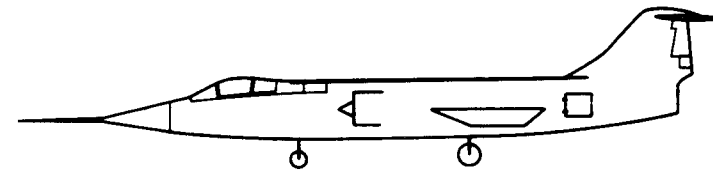
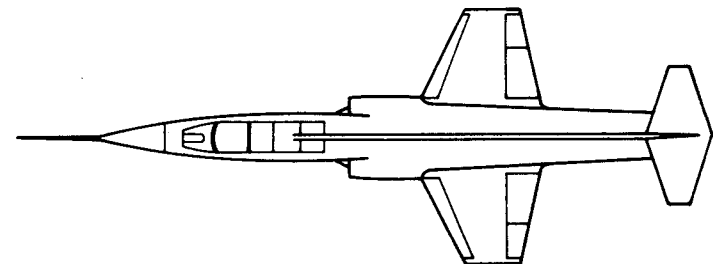
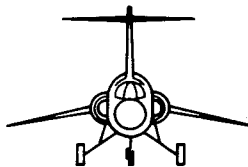
FLIGHT CONDITIONS

		1	2	3	4	5
		Takeoff	Start Cruise	End Cruise	V _{MAX}	V _{MAX} Sea Level
	h (ft)	Sea Level	30,000	30,000	30,000	Sea Level
	M	.273	.84	1.0	1.9	1.36
	W (lb)	24,000	23,310	14,960	15,000	15,000
	x _{CG} /c	.046	.040	.18	.18	.18
External Tanks	Tip	On	On	Clean	Clean	Clean
	Pylon	On	On	Clean	Clean	Clean
Flaps	Leading Edge	-15°	-3°	-3°	-3°	-3°
	Trailing Edge	15°	15°	0°	0°	0°

Note: Lateral data not available

REFERENCE GEOMETRY

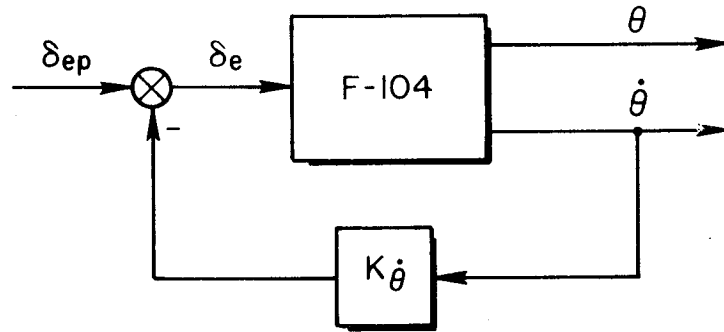
- S = 196 ft²
- b = 21.9 ft
- c = 9.53 ft



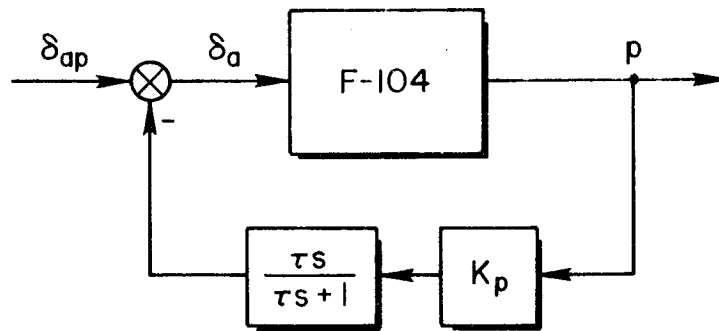
REFERENCES

Unpublished Data

PITCH :



ROLL :



YAW :

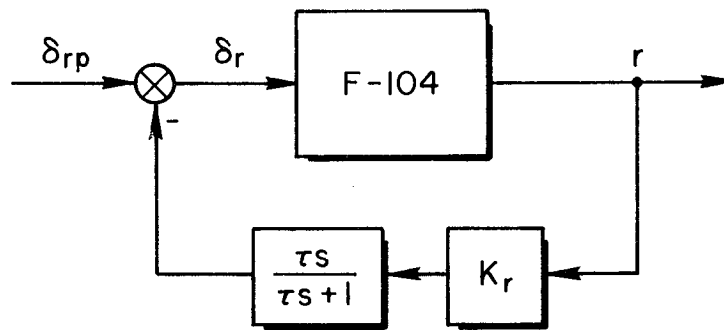


Figure VII-2. F-104 — Stability Augmentation System

TABLE VII-A

GEOMETRICAL AND INERTIAL PARAMETERS FOR THE F-104

Note: Data are for body-fixed stability axes

$$S = 196.1 \text{ ft}^2, \quad c = 9.53 \text{ ft}, \quad b = 21.9 \text{ ft}$$

	FLIGHT CONDITION				
	1 TAKEOFF	2 START CRUISE	3 END CRUISE	4 V_{\max}	5 V_{\max} SEA LEVEL
h (ft)	Sea Level	30,000	30,000	30,000	Sea Level
M (-)	0.273	0.84	1.0	1.9	1.36
a (ft/sec)	1117	995	995	995	1117
ρ (slugs/ft ³)	0.00238	0.000889	0.000889	0.000889	0.00238
V_{T_0} (ft/sec)	305	836	995	1892	1519
$\bar{q} = \rho V^2/2$ (lb/ft ²)	110.5	310	440	1590	2740
W (lb)	24,000	23,310	14,960	15,000	15,000
m (slugs)	746	724.5	465	466	466
I_y (slug-ft ²)	65,000	64,500	56,650	56,650	56,650
$x_{c.g.}/\bar{c}$	0.046	0.040	0.18	0.18	0.18
α_0 (deg)	19.6	4.0	2.0	1.4	1.1
γ_0 (deg)	10	0	0	0	0
θ_0 (deg)	29.6	4.0	2.0	1.4	1.1

TABLE VII-B

LONGITUDINAL NONDIMENSIONAL DERIVATIVES FOR THE F-104

Note: Data are for body-fixed stability axes.

	FLIGHT CONDITION				
	1	2	3	4	5
h (ft)	0	30,000	30,000	30,000	0
M (-)	0.237	0.84	1.0	1.9	1.36
C_L	1.125	0.342	0.1375	0.0383	0.0278
C_D	0.185	0.0365	0.04	0.041	0.045
$C_{L\alpha}$	4.44	4.97	5.10	2.92	4.18
$C_{L\dot{\alpha}}$	0	0	0	0	0
C_{LM}	0	0	0	0	0
$C_{L\delta_e}$	0.762	1.015	1.071	0.6925	0.8035
$C_{D\alpha}$	0	0.1094	0.0255	0	0
C_{DM}	0	0.038	0.040	0.042	0.045
$C_{D\delta_e}$	0	0	0	0	0
$C_{m\alpha}$	-1.496	-1.319	-1.564	-1.255	-1.80
$C_{m\dot{\alpha}}$	-3.44	-3.90	-4.99	-3.04	-2.005
C_{mM}	0	0	0	0	0
C_{mq}	-5.615	-8.03	-8.60	-4.59	-6.825

TABLE VII-C

LONGITUDINAL DIMENSIONAL DERIVATIVES FOR THE F-104

Note: Data are for body-fixed stability axes.

	FLIGHT CONDITION				
	1 TAKEOFF	2 START CRUISE	3 END CRUISE	4 V_{max}	5 V_{max} SEA LEVEL
h (ft)	Sea Level	30,000	30,000	30,000	Sea Level
M (-)	0.273	0.84	1.0	1.9	1.36
X_u (1/sec)	-0.0352	-0.0106	-0.0224	-0.0573	-0.115
X_w (1/sec)	0.107	0.0234	0.0209	0.0136	0.0211
X_{δ_e} [(ft/sec ²)/rad]	0	0	0	0	0
Z_u (1/sec)	-0.214	-0.0688	-0.0513	-0.0271	-0.0422
Z_w (-)	0	0	0	0	0
$Z_{\dot{w}}$ (1/sec)	-0.440	-0.504	-0.959	-1.05	-3.21
Z_{δ_e} [(ft/sec ²)/rad]	-22.1	-85.3	-199	-464	-927
M_u (1/sec-ft)	0	0	0	0	0
M_w (1/ft)	-0.00056	-0.000239	-0.000349	-0.000212	-0.000375
$M_{\dot{w}}$ (1/sec-ft)	-0.0156	-0.0142	-0.0228	-0.0348	-0.107
M_q (1/sec)	-0.279	-0.412	-0.598	-0.607	-1.94
M_{δ_e} (1/sec ²)	-4.67	-17.8	-30.8	-57.2	-140

TABLE VII-D

ELEVATOR LONGITUDINAL TRANSFER FUNCTION FACTORS FOR THE F-104

Note: Data are for body-fixed stability axes

		FLIGHT CONDITION				
		1 TAKEOFF	2 START CRUISE	3 END CRUISE	4 V_{max}	5 V_{max} SEA LEVEL
Mach No., M (-)		0.273	0.84	1.0	1.9	1.36
Altitude, h (ft)		Sea Level	30,000	30,000	30,000	Sea Level
CG (% c)		4.6	4.0	18	18	18
Weight, W (lb)		24,000	23,310	14,960	15,000	15,000
Δ_{long}	ζ_{sp}	0.206	0.161	0.197	0.126	0.220
	ω_{sp}	2.21	3.48	4.83	8.16	13.0
	$\zeta_p (1/T_{p1})$	0.0532	0.102	0.277	(0.00959)	(0.00808)
	$\omega_p (1/T_{p2})$	0.145	0.051	0.0402	(0.0477)	(0.107)
$N_{\delta e}^{\theta}$	A_{θ}	-4.66	-17.8	-30.7	-57.1	-140
	$1/T_{\theta 1}$	0.133	0.0144	0.0237	0.0578	0.115
	$1/T_{\theta 2}$	0.269	0.432	0.812	0.767	2.51
$N_{\delta e}^u$	A_u	-2.37	-2.00	-4.15	-6.29	-19.6
	$1/T_{u1}$	-0.0391	1.11	2.26	3.61	24.8
	$1/T_{u2}$	6.17	-113	-85.7	-62.2	-23.2
$N_{\delta e}^w$	A_w	-22.1	-85.3	-199	-464	-927
	$1/T_{w1}$	64.7	175	155	234	231
	$\zeta_w (1/T_{w2})$	0.0566	0.102	0.275	(0.00967)	(0.00833)
	$\omega_w (1/T_{w3})$	0.147	0.0514	0.0407	(0.0476)	(0.107)
$N_{\delta e}^h$	A_h	21.8	85.3	199	464	927
	$1/T_{h1}$	0.0185	0.00816	0.0217	0.0571	0.115
	$1/T_{h2}$	5.21	9.03	11.7	13.9	25.2
	$1/T_{h3}$	-4.76	-8.41	-10.7	-12.9	-22.7

SECTION VIII

F-105B

F-105B

Figure VIII-1

FLIGHT CONDITIONS

	1*	2*	3	4	5
Takeoff	Start Cruise	End Cruise	Power Approach	V _{max}	
h (ft)	Sea Level	35,000	35,000	Sea Level	40,000
M	.261	.9	.9	.241	2.1
W(lb)	41,230	41,230	35,370	30,000	35,370
x _{G/c}	.295	.295	.308	.308	.308
External Tanks	Centerline	1-650gal.	Clean	Clean	Clean
	Wing Pylon	2-450gal.	Clean	Clean	Clean
Flaps	Leading Edge	20°	0	0	0
	Trailing Edge	46°	0	0	0

* Lateral data not available at these conditions

REFERENCE GEOMETRY

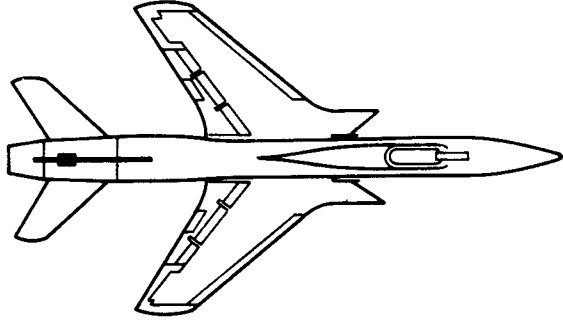
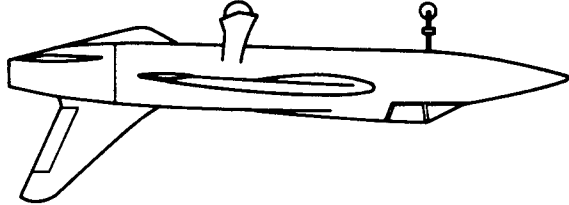
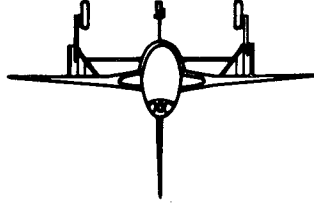
S = 385 ft²

b = 34.9 ft

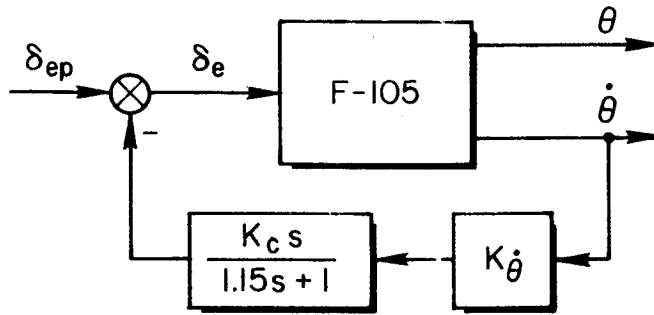
c = 11.5 ft

REFERENCES

Unpublished Data

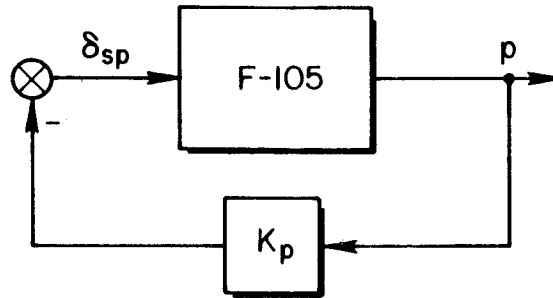


PITCH:



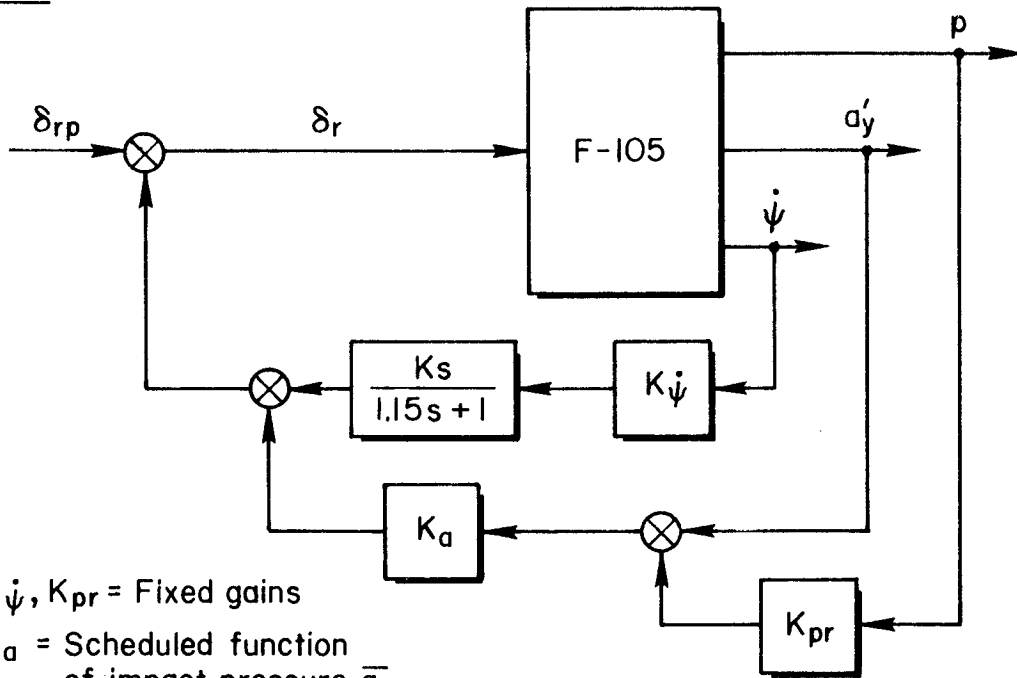
$K_{\dot{\theta}}$ = Scheduled function of impact pressure \bar{q}_c

ROLL:



K_p = Scheduled function of impact pressure \bar{q}_c

YAW:



$K_{\dot{\psi}}, K_{pr}$ = Fixed gains
 K_a = Scheduled function of impact pressure \bar{q}_c

Figure VIII-2. F-105 — Stability Augmentation System

TABLE VIII-A

GEOMETRICAL AND INERTIAL PARAMETERS FOR THE F-105B

Note: Inertia data are for principal axes.

$$s = 385 \text{ ft}^2, b = 34.9 \text{ ft}, c = 11.5 \text{ ft}$$

	FLIGHT CONDITION				
	1 TAKEOFF	2 START CRUISE	3 END CRUISE CLEAN	4 POWER APPROACH CLEAN	5 V_{\max} CLEAN
h (ft)	Sea Level	35,000	35,000	Sea Level	40,000
M (-)	0.261	0.9	0.9	0.241	2.1
a (ft/sec)	1117	973.3	973.3	1117	968.5
ρ (slugs/ft ³)	0.00237	0.000738	0.000738	0.00237	0.000587
V_{T_0} (ft/sec)	291	875	875	269	2030
$\bar{q} = \rho V^2/2$ (lb/ft ²)	100	283	283	86	1210
W (lb)	41,230	41,230	35,370	30,000	35,370
m (slugs)	1280	1280	1098	932	1098
I_x (slug-ft ²)	8,700	8,700	10,300	12,600	10,300
I_y (slug-ft ²)	140,000	140,000	140,000	140,000	140,000
I_z (slug-ft ²)	185,000	185,000	181,000	177,000	181,000
I_{xz} (slug-ft ²)	0	0	0	0	0
$x_{c.g.}/\bar{c}$	0.295	0.295	0.308	0.308	0.308
α_0 (deg)	7.4	7.2	7.0	5.2	3.5
γ_0 (deg)	10.0	0	0	-5.0	0
θ_0 (deg)	17.4	7.2	7.0	0.2	3.5

TABLE VIII-B

LONGITUDINAL DIMENSIONAL DERIVATIVES FOR THE F-105B

Note: Data are for body-fixed stability axes.

	FLIGHT CONDITION				
	1 TAKEOFF	2 START CRUISE	3 END CRUISE CLEAN	4 POWER APPROACH CLEAN	5 V_{\max} CLEAN
h (ft)	Sea Level	35,000	35,000	Sea Level	40,000
M (-)	0.261	0.9	0.9	0.241	2.1
X_u (1/sec)	-0.029	-0.00582	-0.00565	-0.0263	-0.00751
X_w (1/sec)	0.0793	0.00693	0.0264	0.086	0.0132
X_{δ_e} [(ft/sec ²)/rad]	0	0	0	0	0
Z_u (1/sec)	-0.1585	-0.01386	-0.0527	-0.1719	-0.0265
Z_w (-)	0	0	0	0	0
$Z_{\dot{w}}$ (1/sec)	-0.311	-0.4	-0.466	-0.406	-0.590
Z_{δ_e} [(ft/sec ²)/rad]	-17.3	-65.19	-75.97	-19.88	-135.9
M_u (1/sec-ft)	-0.0000119	0	0	-0.0000101	-0.0000198
M_w (1/ft)	-0.000259	-0.000117	-0.000117	-0.000259	-0.00000535
$M_{\dot{w}}$ (1/sec-ft)	-0.00575	-0.00819	-0.00468	-0.00324	-0.01252
M_q (1/sec)	-0.345	-0.485	-0.485	-0.319	-0.303
M_{δ_e} (1/sec ²)	-2.60	-12.03	-12.03	-2.703	-21.0

TABLE VIII-C

LATERAL DIMENSIONAL DERIVATIVES FOR THE F-105B

Note: Data are for body-fixed stability axes, lateral data not available for flight conditions 1 and 2.

	FLIGHT CONDITION		
	3 END CRUISE CLEAN	4 POWER APPROACH CLEAN	5 V_{max} CLEAN
h (ft)	35,000	Sea Level	40,000
M (-)	0.9	0.241	2.1
Y_V (1/sec)	-0.1497	-0.1878	-0.213
$Y_{\delta_a}^*$ [(1/sec)/rad]	-0.00173	-0.0021	-0.00221
$Y_{\delta_r}^*$ [(1/sec)/rad]	0.0234	0.0241	0.0837
L_p^* (1/sec ²)	-41.1	-21.5	-139.8
L_p^* (1/sec)	-2.8	-1.185	-3.14
L_r^* (1/sec)	1.709	1.251	1.966
$L_{\delta_a}^*$ (1/sec ²)	10.71	3.72	26.5
$L_{\delta_r}^*$ (1/sec ²)	14.37	2.86	12.97
N_{β}^* (1/sec ²)	12.39	4.38	18.81
N_p^* (1/sec)	0.324	0.0725	0.1341
N_r^* (1/sec)	-0.382	-0.242	-0.386
$N_{\delta_a}^*$ (1/sec ²)	-1.086	-0.277	-1.339
$N_{\delta_r}^*$ (1/sec ²)	-4.71	-0.975	-1.989

TABLE VIII-D

ELEVATOR LONGITUDINAL TRANSFER FUNCTION FACTORS FOR THE F-105B

Note: Data are for body-fixed stability axes.

		FLIGHT CONDITION				
		1 TAKEOFF	2 START CRUISE	3 END CRUISE CLEAN	4 POWER APPROACH CLEAN	5 V_{max} CLEAN
Mach No., M (-)		0.261	0.9	0.9	0.241	2.1
Altitude h (ft)		Sea Level	35,000	35,000	Sea Level	40,000
CG (% \bar{c})		29.5	29.5	30.8	30.2	30.8
Weight, W (lb)		41,230	41,230	35,370	30,000	35,370
Δ_{long}	ζ_{sp}	0.281	0.1819	0.253	0.398	0.0893
	ω_{sp}	1.338	2.71	2.08	0.998	5.06
	ζ_p	0.0297	0.1295	0.0631	0.1016	0.1869
	ω_p	0.1247	0.0223	0.0429	0.1342	0.0201
$N_{\delta e}^{\theta}$	A_{θ}	-2.60	-12.03	-12.02	-2.70	-21.0
	$1/T_{\theta 1}$	0.1026	0.0061	0.00891	0.0742	0.00827
	$1/T_{\theta 2}$	0.200	0.355	0.433	0.335	0.508
$N_{\delta e}^u$	A_u	-1.367	-0.452	-2.002	-1.708	-1.792
	$1/T_{u 1}$	1.018	0.438	1.511	1.266	2.94
	$1/T_{u 2}$	-17.0	-696	-55.8	-15.02	-65.2
$N_{\delta e}^w$	A_w	-17.27	-65.2	-76.0	-19.88	-135.9
	$1/T_{w 1}$	44.2	162	-139	36.9	315
	ζ_w	0.0372	0.129	0.0642	0.1258	0.1838
	α_w	0.1287	0.0225	0.044	0.1435	0.0204
$N_{\delta e}^{\dot{h}}$	$A_{\dot{h}}$	17.28	65.2	76.0	19.88	135.9
	$1/T_{\dot{h} 1}$	0.01292	0.00466	0.00439	0.01094	0.00737
	$1/T_{\dot{h} 2}$	-3.37	-7.29	-7.48	-3.49	-12.49
	$1/T_{\dot{h} 3}$	3.80	7.88	8.07	3.89	12.8

TABLE VIII-E

AILERON LATERAL TRANSFER FUNCTION FACTORS FOR THE F-105B

Note: Data are for body-fixed stability axes; lateral data not available for flight conditions 1 and 2.

		FLIGHT CONDITION		
		3 END CRUISE CLEAN	4 POWER APPROACH CLEAN	5 V_{max} CLEAN
Mach No., M (-)		0.9	0.241	2.1
Altitude, h (ft)		35,000	Sea Level	40,000
CG (% \bar{c})		30.8	30.2	30.8
Weight, W (lb)		35,370	30,000	35,370
α_0 (deg)		7.0	5.2	3.5
Δ_{lat}	$1/T_s$	-0.00870	0.000676	0.00631
	$1/T_R$	2.13	1.382	2.95
	ζ_d	0.184	0.0545	0.1531
	ω_d	3.29	2.13	4.16
$N_{\delta a}^p$	A_p	10.71	3.72	26.5
	$1/T_{p1}$	0	0.0103	0
	ζ_p	0.0635	0.101	0.0744
	ω_p	2.87	1.674	3.44
$N_{\delta a}^r$	A_r	-1.086	-0.277	-1.339
	$1/T_{r1}$	-1.524	-1.503	-1.3
	ζ_r	0.465	0.564	0.600
	ω_r	1.398	1.718	1.686
$N_{\delta a}^B$	A_B	-0.00174	-0.00210	-0.00221
	$1/T_{B1}$	-622	0.1427	0.1379
	$1/T_{B2}$ (ζ_B)	(-0.0573)	1.655	0.658
	$1/T_{B3}$ (ω_B)	(0.276)	-133.7	601

TABLE VIII-F

RUDDER LATERAL TRANSFER FUNCTION FACTORS FOR THE F-105B

Note: Data are for body-fixed stability axes; lateral data not available for flight conditions 1 and 2.

		FLIGHT CONDITION		
		3 END CRUISE CLEAN	4 POWER APPROACH CLEAN	5 V_{max} CLEAN
Mach No., M (-)		0.9	0.241	2.1
Altitude, h (ft)		35,000	Sea Level	40,000
CG (% \bar{c})		30.8	30.2	30.8
Weight, W (lb)		35,370	30,000	35,370
α_o (deg)		7.0	5.2	3.5
Δ_{lat}	$1/T_s$	-0.00870	0.000676	0.00631
	$1/T_R$	2.13	1.382	2.45
	ζ_d	0.184	0.0545	0.1531
	ω_d	3.29	2.13	4.16
$N_{\delta_r}^p$	A_p	14.37	2.86	12.97
	$1/T_{p1}$	0	0.0103	0
	$1/T_{p2}$	-1.109	-1.82	-1.499
	$1/T_{p3}$	1.014	1.63	1.738
$N_{\delta_r}^r$	A_r	-4.71	-0.975	-1.989
	$1/T_{r1}$	1.848	1.463	2.31
	ζ_r	0.1028	-0.246	0.1601
	ω_r	0.259	0.838	0.342
$N_{\delta_r}^b$	A_β	0.0233	0.0241	0.00538
	$1/T_{\beta1}$	-0.0103	-0.0395	0.00369
	$1/T_{\beta2}$	1.927	1.371	2.36
	$1/T_{\beta3}$	203	40.6	370

PRECEDING PAGE

NOT FILMED

SECTION IX

B-58

Preceding page blank

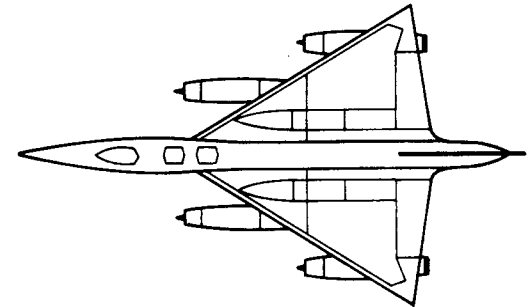
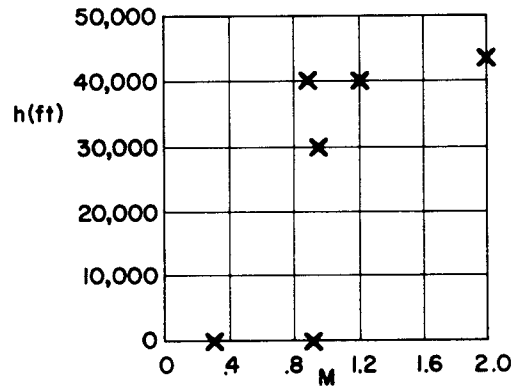
Figure IX-1

B-58

NOMINAL CRUISE CONFIGURATION

See Table IX-A

FLIGHT CONDITIONS

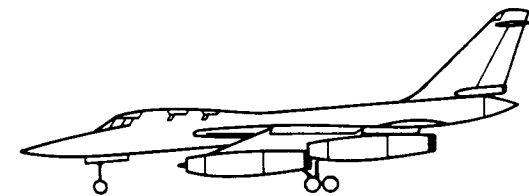
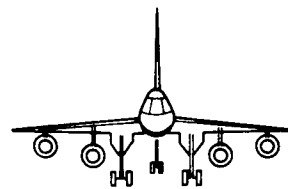


REFERENCE GEOMETRY

- S = 1542 ft²
- b = 56.8 ft
- c = 36.2 ft

REFERENCES

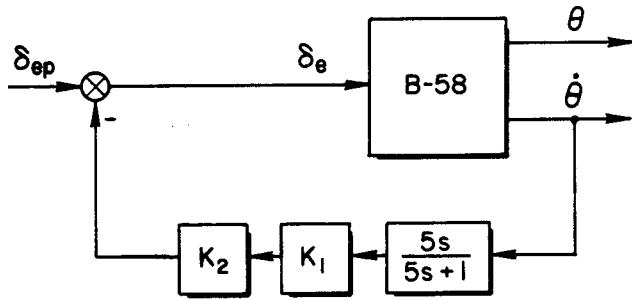
- 1) Bright, B.E., Ellington, J.D., "Application of the Limit-Cycle Selfadaptive Concept to the B-58 Lateral Directional Stability Augmentation System." Thesis, Air Force Institute of Technology, GGC/EE/64-5, May 1964
- 2) Anon., "B-58 Flight Control System", Gen. Dyn. Fort Worth, FZE-4-049, Nov. 1962
- 3) Jones, L.S., "U.S. Bombers BI-B70" Aero Publishing Inc., 1962



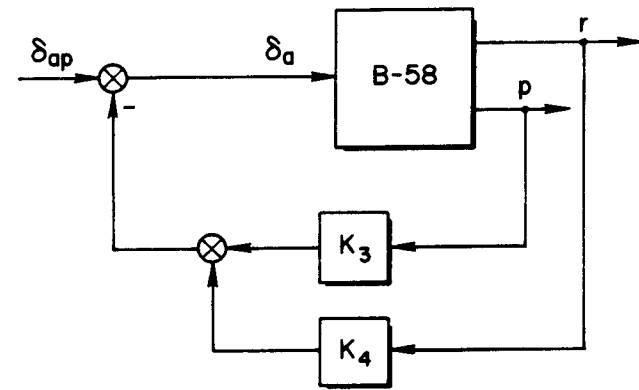
SOURCE

Unknown

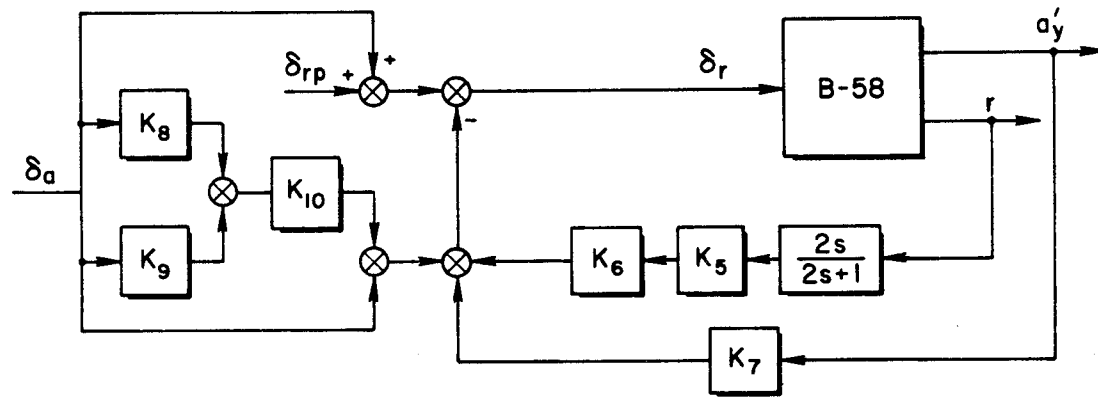
PITCH



ROLL



YAW



NOTE:

K_1, K_4, K_5, K_7, K_8 ... Gains Scheduled for Mach-Number

$K_2, K_3, K_6, K_9, K_{10}$... Gains Scheduled for Altitude

(Air data computer not shown)

The Augmentation System for this airplane is known to have undergone several modifications. The system shown is of 1962 vintage as documented in G.D.Convair Report FZE 4-052, Dec. 1962, being the latest available data

Figure IX-2. B-58 — Stability Augmentation System

GEOMETRICAL PARAMETERS FOR THE B-58

TABLE IX-A

Note: Data for body-fixed stability axes, cruise configuration.

$$s = 1,542 \text{ ft}^2; b = 56.82 \text{ ft}; c = 36.17 \text{ ft}$$

FLIGHT CONDITION							
	1	2	3	4	5	6	7
h (ft)	0	0	0	40,000	44,200	30,000	40,000
M (-)	0.32	0.91	0.91	0.91	2.0	0.98	1.2
a (ft/sec)	1117	1117	1117	968	968	995	968
σ (slugs/ft ²)	0.002377	0.002377	0.002377	0.000585	0.000478	0.000889	0.000585
V_{T0} (ft/sec)	357	1016	1016	881	1936	975	1162
$\bar{q} = \rho V_{T0}^2 / 2$ (lb/ft ²)	152	1227	1227	228	900	423	396
W (lbs)	150,000	90,000	150,000	150,000	150,000	150,000	150,000
m (slugs)	4655	2788	4655	4655	4655	4655	4655
I_x (slugs-ft ²)	430,070	335,344	386,860	363,365	362,502	361,275	361,484
I_y (slugs-ft ²)	1,045,000	649,892	1,045,000	1,045,000	1,045,000	1,045,000	1,045,000
I_z (slugs-ft ²)	1,402,030	950,080	1,445,230	1,206,610	1,208,110	1,207,210	1,208,490
I_{xz} (slugs-ft ²)	-215,646	19,250	51,375	-39,871	27,186	10,722	-553
γ (deg)	0	0	0	0	0	0	0
x_{CG}/c	0.28	0.28	0.28	0.30	0.33	0.33	0.33

TABLE IX-B

LATERAL NONDIMENSIONAL STABILITY DERIVATIVES FOR THE B-58

Note: Data are for body-fixed stability axes, cruise configuration.

	FLIGHT CONDITION						
	1	2	3	4	5	6	7
h (ft)	0	0	0	40,000	44,200	30,000	40,000
M (-)	0.32	0.91	0.91	0.91	2.0	0.98	1.2
V_{T_0} (ft/sec)	357.3	1016	1016	880.9	1936.2	975	1161.7
$C_{y\beta}$	-0.6395	-0.6375	-0.674	-0.7665	-0.6275	-0.732	-0.801
$C_{y\delta_a}$	0.1511	0.08655	0.0890	0.1790	0.0187	0.1862	0.1791
$C_{y\delta_r}$	0.0929	0.0527	0.05725	0.0954	0.0232	0.08075	0.0545
$C_{l\beta}$	-0.1584	-0.0551	-0.0851	-0.1345	-0.03942	-0.1096	-0.1158
C_{lp}	-0.1936	-0.1585	-0.1576	-0.2173	-0.2317	-0.2107	-0.2238
C_{lr}	0.04479	0.08568	0.08553	0.1102	0.07207	0.09543	0.1071
$C_{l\delta_a}$	-0.1112	-0.04043	-0.03892	-0.1041	-0.01782	-0.0729	-0.0010
$C_{l\delta_r}$	0.001927	0.00729	0.007395	0.01227	0.003115	0.01328	0.0078
$C_{n\beta}$	0.1014	0.1242	0.0624	0.1029	0.03207	0.0788	0.1117
C_{np}	-0.1143	-0.01082	-0.02935	-0.06118	0.01241	-0.03713	-0.04215
C_{nr}	-0.2494	-0.2449	-0.2312	-0.2868	-0.2132	-0.2611	-0.2823
$C_{n\delta_a}$	-0.0405	-0.03318	-0.03317	-0.0664	-0.02038	-0.0725	-0.09275
$C_{n\delta_r}$	-0.06415	-0.03561	-0.03563	-0.0633	-0.01382	-0.0530	-0.03255

TABLE IX-C

LATERAL DIMENSIONAL DERIVATIVES FOR THE B-58

Note: Data for body-fixed stability axes, cruise configuration.

	FLIGHT CONDITION						
	1	2	3	4	5	6	7
h (ft)	0	0	0	40,000	44,200	30,000	40,000
M (-)	0.32	0.91	0.91	0.91	2.0	0.98	1.2
Y_V	-0.09	-0.426	-0.27	-0.0654	-0.0962	-0.105	-0.09
$Y_{\delta_a}^*$	0.0212	0.0578	0.0356	0.0153	0.00287	0.0267	0.0201
$Y_{\delta_r}^*$	0.0131	0.0382	0.0229	0.00814	0.00356	0.0116	0.00613
L_{β}^{\prime}	-5.828	-16.875	-23.14	-7.575	-8.394	-11.163	-11.08
L_p^{\prime}	-0.469	-1.424	-1.238	-0.381	-0.736	-0.63	-0.524
L_r^{\prime}	0.221	0.724	0.603	0.212	0.214	0.278	0.251
$L_{\delta_a}^{\prime}$	-3.516	-13.19	-11.194	-5.597	-3.965	-7.538	-0.953
$L_{\delta_r}^{\prime}$	0.395	2.108	1.71	0.789	0.608	1.313	0.748
N_{β}^{\prime}	1.858	13.71	3.818	1.946	1.895	2.317	3.202
N_p^{\prime}	-0.0141	-0.0631	-0.105	-0.02	-0.00473	-0.0388	-0.0293
N_r^{\prime}	-0.222	-0.76	-0.459	-0.159	-0.198	-0.231	-0.198
$N_{\delta_a}^{\prime}$	0.157	-4.021	-2.865	-0.909	-1.413	-2.29	-2.654
$N_{\delta_r}^{\prime}$	-0.669	-3.986	-2.589	-1.069	-0.884	-1.614	-0.932

TABLE IX-D

AILERON LATERAL TRANSFER FUNCTION FACTORS FOR THE B-58

Note: Data are for body-fixed stability axes, cruise configuration

		FLIGHT CONDITION						
		1	2	3	4	5	6	7
h (ft)		0	0	0	40,000	44,200	30,000	40,000
M (-)		0.32	0.91	0.91	0.91	2.0	0.98	1.2
Δ	$1/T_s$	0.058	0.00426	0.0334	0.026	0.0134	0.029	0.017
	$1/T_R$	0.698	1.527	1.75	0.556	0.802	0.885	0.687
	ζ_d	0.009	0.144	0.044	0.0086	0.0772	0.0165	0.0296
	ω_d	1.403	3.756	2.126	1.42	1.40	1.58	1.81
$N_{\delta_a}^p$	A_p	-3.516	-13.19	-11.194	-5.597	-3.965	-7.538	-0.953
	$1/T_{p1}$	0	0	0	0	0	0	0
	ζ_p	0.132	0.168	0.152	0.0784	0.085	0.096	0.104
	ω_p	1.274	4.391	3.151	1.786	2.217	2.398	5.85
$N_{\delta_a}^r$	A_r	0.157	-4.021	-2.865	-0.909	-1.413	-2.29	-2.654
	$1/T_R$	-1.148	1.881	1.498	1.002	0.983	1.082	0.934
	ζ_r	0.678	-0.213	-0.249	-0.420	-0.174	-0.331	-0.295
	ω_r	1.677	1.021	0.897	0.845	0.481	0.757	0.602
$N_{\delta_a}^\beta$	A_β	0.0212	0.0578	0.0356	0.0153	0.00287	0.0267	0.0202
	$1/T_{\beta 1} (\zeta_\beta)$	0.1624	-0.0838	-0.0941	-0.191	-0.0184	-0.073	-0.0171
	$1/T_{\beta 2} (\omega_\beta)$	2.1616	1.198	0.798	0.226	0.695	0.467	0.520
	$1/T_{\beta 3}$	-9.008	70.64	81.472	60.03	493.37	86.15	131.87
$N_{\delta_a}^{a_y}$ CG	A_{a_y}	7.594	58.73	36.17	13.46	5.55	26.063	23.42
	$1/T_{a_y 1} (\zeta_{a_y 2})$	0.12	-0.210	-0.183	0.15	-0.02	-0.161	-0.036
	$1/T_{a_y 2} (\omega_{a_y 2})$	1.009	0.948	0.593	1.839	0.69	0.35	0.458
	$\zeta_{a_y 3} (1/T_{a_y 3})$	-0.127	(-3.3)	(-3.608)	-0.852	(-6.618)	(-2.255)	(-2.8)
	$\omega_{a_y 3} (1/T_{a_y 4})$	1.733	(4.744)	(4.896)	0.85	(6.883)	(2.927)	(3.097)

TABLE IX-E

RUDDER LATERAL TRANSFER FUNCTION FACTORS FOR THE B-58

Note: Data for body-fixed stability axes, cruise configuration

		FLIGHT CONDITION						
		1	2	3	4	5	6	7
h (ft)		0	0	0	40,000	44,200	30,000	40,000
M (-)		0.32	0.91	0.91	0.91	2.0	0.98	1.2
Δ	$1/T_S$	0.058	0.00426	0.0334	0.026	0.0134	0.029	0.017
	$1/T_R$	0.698	1.527	1.75	0.556	0.802	0.885	0.687
	ζ_d	0.009	0.144	0.044	0.0086	0.0772	0.0165	0.0296
	ω_d	1.403	3.756	2.126	1.42	1.40	1.58	1.81
$N_{\delta_p}^p$	A_p	0.395	2.108	1.711	0.789	0.608	1.313	0.748
	$1/T_{p1}$	0	0	0	0	0	0	0
	$1/T_{p2}$	-2.969	-4.554	-5.859	-2.959	-3.247	-3.433	-3.319
	$1/T_{p3}$	2.713	4.065	5.365	2.818	3.181	3.329	3.204
$N_{\delta_r}^r$	A_r	-0.669	-3.986	-2.589	-1.069	-0.884	-1.614	-0.932
	$1/T_r$	0.964	1.607	1.615	0.786	0.901	1.0	0.88
	ζ_r	-0.326	0.167	-0.0561	-0.317	-0.10	-0.226	-0.255
	ω_r	0.665	0.436	0.636	0.534	0.362	0.553	0.518
$N_{\delta_r}^{\beta}$	A_{β}	0.0131	0.0382	0.0229	0.00814	0.00355	0.0116	0.00613
	$1/T_{\beta 1}$	-0.0149	-0.00685	-0.00709	-0.008	-0.00171	-0.0043	-0.00445
	$1/T_{\beta 2}$	0.546	1.482	1.337	0.431	0.753	0.693	0.574
	$1/T_{\beta 3}$	51.355	150.05	113.43	131.44	248.84	139.37	152.06
$N_{\delta_r}^{ay}$	A_{ay}	4.669	38.813	23.266	7.173	6.886	11.303	7.126
	$1/T_{ay1} (\zeta_{ay2})$	-0.0966	-0.0122	-0.0167	-0.0225	-0.0032	-0.0135	-0.0131
	$1/T_{ay2} (\omega_{ay2})$	0.446	1.46	1.243	0.394	0.748	0.649	0.537
	$\zeta_{ay3} (1/T_{ay3})$	(-1.486)	(-5.179)	(-4.926)	(-2.492)	(-4.597)	(-3.394)	(-3.14)
	$\omega_{ay3} (1/T_{ay4})$	(1.828)	(5.915)	(5.398)	(2.662)	(4.788)	(3.62)	(3.338)

SECTION X

NAVION

Figure X-1

NAVIONNOMINAL FLIGHT CONDITION

$$h(\text{ft}) = 0 ; M = .158 ; V_{T_0} = 176 \text{ ft/sec}$$

$$W = 2750 \text{ lbs}$$

CG at 29.5 % MAC

$$I_x = 1048 \text{ slug ft}^2$$

$$I_y = 3000 \text{ slug ft}^2$$

$$I_z = 3530 \text{ slug ft}^2$$

$$I_{xz} = 0$$

REFERENCE GEOMETRY

$$S = 184 \text{ ft}^2$$

$$c = 5.7 \text{ ft}$$

$$b = 33.4 \text{ ft}$$

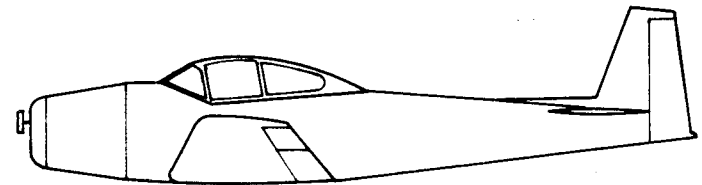
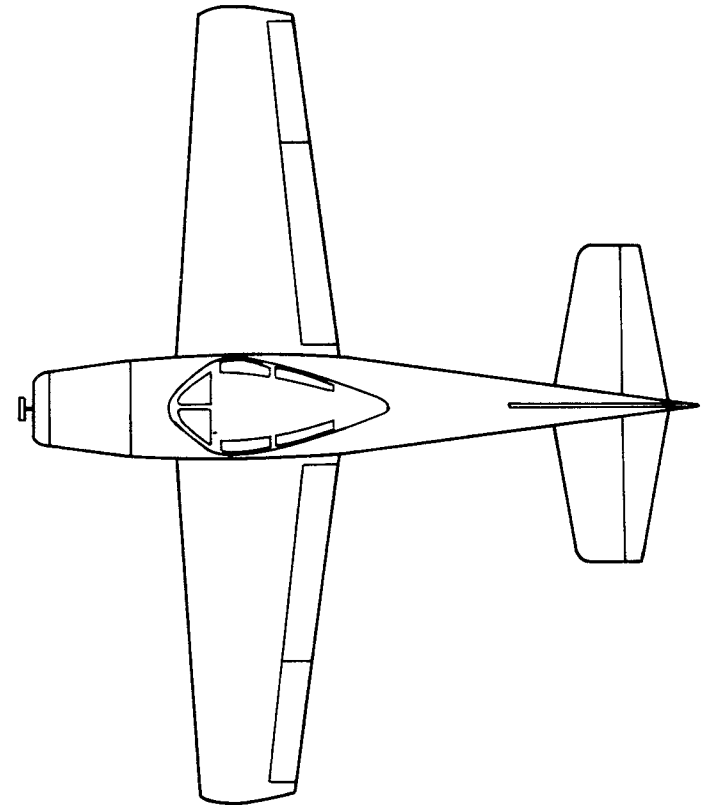
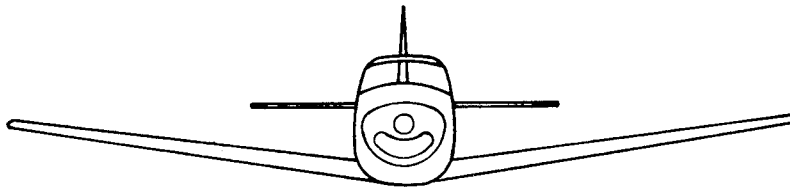


TABLE X-A

GEOMETRICAL PARAMETERS
FOR THE NAVION

Note: Data for body-fixed stability axes, level flight	
S (ft ²)	180
b (ft)	33.4
c (ft)	5.7
W (lb)	2,750
m (slugs)	85.4
c.g. (% MAC)	29.5
I _x (slug-ft ²)	1,048
I _y (slug-ft ²)	3,000
I _z (slug-ft ²)	3,530
I _{xz}	0
h (ft)	0
M	0.158
a (ft/sec)	1117
ρ (slugs/ft ³)	0.002378
V _{T0} (ft/sec)	176
$\bar{q} = \rho V_{T0}^2 / 2$ (lb/ft ²)	36.8
α ₀ (deg)	0.6
γ ₀ (deg)	0

TABLE X-B

LONGITUDINAL NONDIMENSIONAL
DERIVATIVES FOR THE NAVION

Note: Data are for stability axes	
	FLIGHT CONDITION
	1
h (ft)	0
M (-)	0.158
C _L	0.41
C _D	0.05
C _{Lα}	4.44
C _{Lα̇}	0
C _{LM}	0
C _{Lδ_e}	0.355
C _{Dα}	0.330
C _{DM}	0
C _{Dδ_e}	0
C _{mα}	-0.683
C _{mα̇}	-4.36
C _{mM}	0
C _{m_q}	-9.96

TABLE X-C

LATERAL NONDIMENSIONAL STABILITY
DERIVATIVES FOR THE NAVION

Note: Data are for stability axes	
	FLIGHT CONDITION
	1
h (ft)	0
M (-)	0.158
V _{T0} (ft/sec)	176
α ₀ (deg)	
C _{yβ}	-0.564
C _{yδ_a}	0
C _{yδ_r}	0.157
C _{lβ}	-0.074
C _{l_p}	-0.410
C _{l_r}	0.107
C _{lδ_a}	0.1342
C _{lδ_r}	0.0118
C _{nβ}	0.0701
C _{n_p}	-0.0575
C _{n_r}	-0.125
C _{nδ_a}	-0.00346
C _{nδ_r}	-0.0717

TABLE X-D

LONGITUDINAL DIMENSIONAL
DERIVATIVES FOR THE NAVION

	FLT. COND.
X_w	0.03607
X_u	-0.0451
X_{δ_e}	0
Z_w	-2.0244
Z_u	-0.3697
Z_{δ_e}	-28.17
M_w	-0.04997
M_w^*	-0.005165
M_q	-2.0767
M_u	0
M_{δ_e}	-11.1892

TABLE X-E

LATERAL DIMENSIONAL DERIVATIVES
FOR THE NAVION

	FLT. COND.
Y_v	-0.2543
$Y_{\delta_a}^*$	0
$Y_{\delta_r}^*$	0.0708
L_{β}^{\prime}	-15.982
L_p^{\prime}	-8.402
L_r^{\prime}	2.193
$L_{\delta_a}^{\prime}$	28.984
$L_{\delta_r}^{\prime}$	2.548
N_{β}^{\prime}	4.495
N_p^{\prime}	-0.3498
N_r^{\prime}	-0.7605
$N_{\delta_a}^{\prime}$	-0.2218
$N_{\delta_r}^{\prime}$	-4.597

TABLE X-F

ELEVATOR LONGITUDINAL
TRANSFER FUNCTION
FACTORS FOR THE NAVION

		FLT. COND.
Δ	ζ_{sp}	0.6957
	ω_{sp}	3.6083
	ζ_p	0.0801
	ω_p	0.2137
$N_{\delta e}^l$	A_l	-11.0114
	$1/T_{l1}$	0.05231
	$1/T_{l2}$	1.9164
$N_{\delta e}^u$	A_u	-1.0161
	$1/T_{u1}$	2.401
	$1/T_{u2}$	-280.39
$N_{\delta e}^w$	A_w	-28.171
	$1/T_w$	71.984
	ζ_w	0.0862
	ω_w	0.2563
$N_{\delta e}^h$	A_h	28.171
	$1/T_{h1}$	-10.108
	$1/T_{h2}$	0.0165
	$1/T_{h3}$	13.122
$N_{\delta e}^{az}$	A_{az}	-28.171
	$1/T_{az1}$	0
	$1/T_{az2}$	-10.108
$l_x=0$	$1/T_{az3}$	0.0165
CG	$1/T_{az4}$	13.122

TABLE X-G

AILERON LATERAL TRANSFER
FUNCTION FACTORS
FOR THE NAVION

		FLT. COND.
Δ	$1/T_s$	0.00876
	$1/T_R$	8.435
	ζ_d	0.204
	ω_d	2.385
$N_{\delta a}^p$	A_p	28.984
	$1/T_{p1}$	0
	ζ_p	0.2336
	ω_p	2.136
$N_{\delta a}^r$	A_r	-0.2218
	$1/T_{r1}$	-1.253
	$1/T_{r2}$	1.543
	$1/T_{r3}$	54.071
$N_{\delta a}^{\beta}$	A_{β}	0.2218
	$1/T_{\beta 1}$	0.2285
	$1/T_{\beta 2}$	77.78

TABLE X-H

RUDDER LATERAL TRANSFER
FUNCTION FACTORS
FOR THE NAVION

		FLT. COND.
Δ	$1/T_s$	0.00876
	$1/T_R$	8.435
	ζ_d	0.204
	ω_d	2.385
$N_{\delta r}^p$	A_p	2.548
	$1/T_{p1}$	0
	$1/T_{p2}$	-6.991
	$1/T_{p3}$	3.6061
$N_{\delta r}^r$	A_r	-4.597
	$1/T_r$	8.639
	ζ_r	0.1335
	ω_r	0.5345
$N_{\delta r}^{\beta}$	A_{β}	0.0707
	$1/T_{\beta 1}$	-0.0366
	$1/T_{\beta 2}$	8.795
	$1/T_{\beta 3}$	65.352
$N_{\delta r}^{ay}$	A_{ay}	12.485
	$1/T_{ay1}$	-0.0591
	$1/T_{ay2}$	8.335
	CG	$1/T_{ay3}$
	$1/T_{ay4}$	3.894

PRECEDING PAGE BLANK NOT FILMED.

SECTION XI

DC-8

Preceding page blank

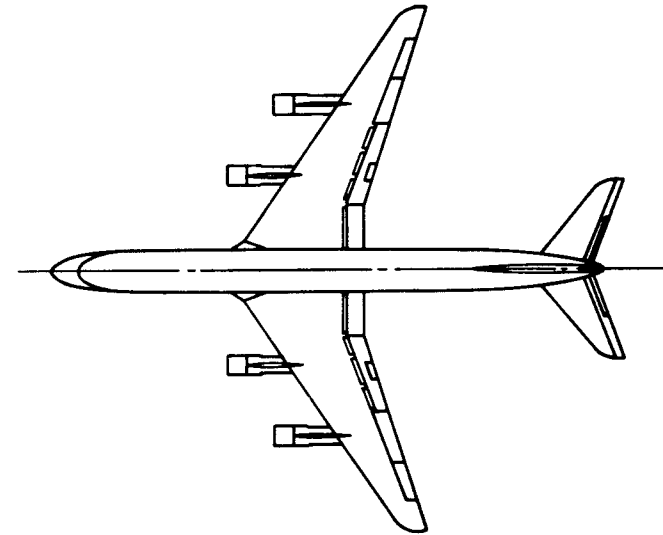
Figure XI-1

DC-8

FLIGHT CONDITIONS

Flight Condition	Approach	Holding	Cruise	V _{NE}
h(ft)	0	15,000	33,000	33,000
M	0.219	0.443	0.84	0.88
W(lbs)	190,000	190,000	230,000	230,000
I _x (slug-ft ²)	3.09 × 10 ⁶	3.11 × 10 ⁶	3.77 × 10 ⁶	3.77 × 10 ⁶
I _y (slug-ft ²)	2.94 × 10 ⁶	2.94 × 10 ⁶	3.56 × 10 ⁶	3.56 × 10 ⁶
I _z (slug-ft ²)	5.58 × 10 ⁶	5.88 × 10 ⁶	7.13 × 10 ⁶	7.13 × 10 ⁶
I _{xz} (slug-ft ²)	28 × 10 ³	-64.5 × 10 ³	45 × 10 ³	53.7 × 10 ³
X _{cg} l \bar{c}	0.15	0.15	0.15	0.15

} Stability Axes



REFERENCE GEOMETRY

S = 2600 ft²

b = 142.3 ft

c = 23 ft

REFERENCES : Unpublished Data

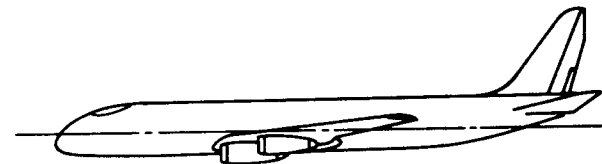
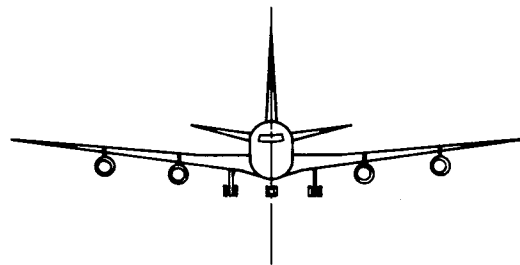


TABLE XI-A

GEOMETRICAL AND INERTIAL PARAMETERS FOR THE DC-8

Note: Data are for body-fixed stability axes

$$S = 2600 \text{ ft}^2, \quad b = 142.3 \text{ ft}, \quad c = 23 \text{ ft}, \quad \gamma_0 = 0 \text{ deg}$$

	FLIGHT CONDITION			
	1 APPROACH	2 HOLDING	3 CRUISE	4 V_{NE}
h (ft)	0	15,000	33,000	33,000
M (-)	0.218	0.443	0.84	0.88
a (ft/sec)	1117	1058	982	982
ρ (slugs/ft ³)	0.002378	0.001496	0.000795	0.000795
V_{T_0} (ft/sec)	243.5	468.2	824.2	863.46
$\bar{q} = \rho V^2/2$ (lb/ft ²)	71.02	163.97	270.0	296.36
W (lb)	190,000	190,000	230,000	230,000
m (slugs)	5900	5900	7143	7143
I_x (slug-ft ²)	3,090,000	3,110,000	3,770,000	3,770,000
I_y (slug-ft ²)	2,940,000	2,940,000	3,560,000	3,560,000
I_z (slug-ft ²)	5,580,000	5,880,000	7,130,000	7,130,000
I_{xz} (slug-ft ²)	28,000	-64,500	45,000	53,700
x_{CG}/c	0.15	0.15	0.15	0.15
θ_0 (deg)	0	0	0	0
U_0 (ft/sec)	243.5	468.2	824.2	863.46
W_0 (ft/sec)	0	0	0	0
δ_F (deg)	35	0	0	0

TABLE XI-B

LONGITUDINAL NONDIMENSIONAL DERIVATIVES FOR THE DC-8

Note: Data are for body-fixed stability axes.

	FLIGHT CONDITION			
	1	2	3	4
h	0	15,000	33,000	33,000
M	0.218	0.443	0.840	0.88
C_L	0.98	0.42	0.308	0.279
C_D	0.1095	0.0224	0.0188	0.0276
$C_{L\alpha}$	4.81	4.8762	6.7442	6.8989
$C_{L\dot{\alpha}}$	0	0	0	0
C_{LM}	0.02	0.048	0	-1.2
$C_{L\delta_e}$	0.328	0.328	0.352	0.358
$C_{D\alpha}$	0.487	0.212	0.2719	0.4862
C_{DM}	0.0202	0.00208	0.1005	0.3653
$C_{D\delta_e}$	0	-0.9712	0	0
$C_{m\alpha}$	-1.478	-1.5013	-2.017	-2.413
$C_{m\dot{\alpha}}$	-3.84	-4.10	-6.62	-6.83
$C_{m\dot{m}}$	-0.006	-0.02	-0.17	-0.50
C_{mq}	-0.00117	-0.9712	-14.6	-15.2

TABLE XI-C

LATERAL NONDIMENSIONAL STABILITY DERIVATIVES FOR THE DC-8

Note: Data are for body-fixed stability axes

	FLIGHT CONDITION			
	1	2	3	4
h (ft)	0	15,000	33,000	33,000
M (-)	0.218	0.443	0.84	0.88
V_{T_0} (ft/sec)	243.5	468.2	824.2	863.46
$C_{y\beta}$	-0.87268	-0.6532	-0.7277	-0.7449
$C_{y\delta_a}$	0	0	0	0
$C_{y\delta_r}$	0.18651	0.18651	0.18651	0.18651
$C_{l\beta}$	-0.15815	-0.13752	-0.16732	-0.17362
C_{lp}	-0.385	-0.416	-0.516	-0.538
C_{lr}	0.248	0.132	0.147	0.146
$C_{l\delta_a}$	-0.08595	-0.08308	-0.07965	-0.07907
$C_{l\delta_r}$	0.02189	0.019195	0.021086	0.02166
$C_{n\beta}$	0.1633	0.12319	0.15471	0.16044
C_{np}	-0.0873	-0.0307	-0.0107	-0.00587
C_{nr}	-0.196	-0.161	-0.190	-0.199
$C_{n\delta_a}$	-0.0106	-0.00354	-0.003701	-0.003999
$C_{n\delta_r}$	-0.08337	-0.08337	-0.08337	-0.08337

TABLE XI-D

LONGITUDINAL DIMENSIONAL DERIVATIVES FOR THE DC-8

Note: Data are for body-fixed stability axes

	FLIGHT CONDITION			
	1	2	3	4
h (ft)	0	15,000	33,000	33,000
M (-)	0.218	0.443	0.84	0.88
T_u (1/sec)	-0.000595	-0.0000846	0.000599	0.000733
$X_{u_{aero}}$ (1/sec)	-0.02851	-0.00707	-0.0145	-0.0471
X_u (1/sec)	-0.0291	-0.00714	-0.014	-0.0463
X_w (1/sec)	0.0629	0.0321	0.0043	-0.0259
X_{δ_e} [(ft/sec ²)/rad]	0	0	0	0
$Z_{u_{aero}}$ (1/sec)	-0.2506	-0.1329	-0.0735	0.0622
Z_u (1/sec)	-0.2506	-0.1329	-0.0735	0.0622
Z_w (-)	0	0	0	0
Z_w (1/sec)	-0.6277	-0.756	-0.806	-0.865
Z_{δ_e} [(ft/sec ²)/rad]	-10.19	-23.7	-34.6	-38.6
$M_{u_{aero}}$ (1/sec-ft)	-0.0000077	-0.000063	-0.000786	-0.00254
M_u (1/sec-ft)	-0.0000077	-0.000063	-0.000786	-0.00254
M_w (1/ft)	-0.001068	-0.00072	-0.00051	-0.00052
M_w (1/sec-ft)	-0.0087	-0.0107	-0.0111	-0.0139
M_q (1/sec)	-0.7924	-0.991	-0.924	-1.008
M_{δ_e} (1/sec ²)	-1.35	-3.24	-4.59	-5.12

TABLE XI-E

LATERAL DIMENSIONAL DERIVATIVES FOR THE DC-8

Note: Data are for body-fixed stability axes

	FLIGHT CONDITION			
	1	2	3	4
h (ft)	0	15,000	33,000	33,000
M (-)	0.218	0.443	0.84	0.88
Y_V (1/sec)	-0.1113	-0.1008	-0.0868	-0.0931
$Y_{\delta_a}^*$ [(1/sec)/rad]	0	0	0	0
$Y_{\delta_r}^*$ [(1/sec)/rad]	0.0238	0.0288	0.0222	0.0233
$I_{\beta}^{\dot{}}$ (1/sec ²)	-1.328	-2.71	-4.41	-5.02
$L_p^{\dot{}}$ (1/sec)	-0.951	-1.232	-1.181	-1.29
$L_r^{\dot{}}$ (1/sec)	0.609	0.397	0.334	0.346
$L_{\delta_a}^{\dot{}}$ (1/sec ²)	-0.726	-1.62	-2.11	-2.3
$L_{\delta_r}^{\dot{}}$ (1/sec ²)	0.1813	0.392	0.549	0.612
$N_{\beta}^{\dot{}}$ (1/sec ²)	0.757	1.301	2.14	2.43
$N_p^{\dot{}}$ (1/sec)	-0.124	-0.0346	-0.0204	-0.01715
$N_r^{\dot{}}$ (1/sec)	-0.265	-0.257	-0.228	-0.25
$N_{\delta_a}^{\dot{}}$ (1/sec ²)	-0.0532	-0.01875	-0.0652	-0.0788
$N_{\delta_r}^{\dot{}}$ (1/sec ²)	-0.389	-0.864	-0.01164	-1.277

TABLE XI-F

ELEVATOR LONGITUDINAL TRANSFER FUNCTION FACTORS FOR THE DC-8

Note: Data are for body-fixed stability axes

		FLIGHT CONDITION			
		1	2	3	4
Mach No., M (-)		0.218	0.443	0.84	0.88
Altitude, h (ft)		0	15,000	33,000	33,000
CG (% \bar{c})		15	15	15	15
Weight, W (lb)		190,000	190,000	230,000	230,000
Δ_{long}	ζ_{sp}	0.522	0.434	0.342	0.325
	ω_{sp}	1.619	2.40	3.15	3.59
	$\zeta_p (1/T_{p1})$	0.0606	0.0310	0.241	(-0.0708)
	$\omega_p (1/T_{p2})$	0.1635	0.0877	0.0243	(0.108)
$N_{\delta_e}^\theta$	A_θ	-1.338	-3.22	-4.57	-5.1
	$1/T_{\theta 1}$	0.0605	0.01354	0.01436	0.0493
	$1/T_{\theta 2}$	0.535	0.675	0.725	0.76
$N_{\delta_e}^u$	A_u	-0.641	-0.761	-0.1489	1.00
	$1/T_{u1}$	1.08	1.279	0.816	0.449
	$1/T_{u2}$	-35.3	-72.7	-879	279
$N_{\delta_e}^w$	A_w	-10.19	-23.7	-34.6	-38.6
	$1/T_{w1}$	33.0	65.0	110.2	-0.0364
	$\zeta_w (1/T_{w2})$	0.0781	0.037	0.1362	(0.0827)
	$\omega_w (1/T_{w3})$	0.1798	0.0947	0.0511	(115.5)
$N_{\delta_e}^{\dot{h}}$	$A_{\dot{h}}$	10.19	23.7	34.6	38.6
	$1/T_{\dot{h}1}$	-3.75	-5.95	-8.24	-8.63
	$1/T_{\dot{h}2}$	-0.00182	-0.000026	0.0107	0.0531
	$1/T_{\dot{h}3}$	4.83	7.29	9.59	100.9
$N_{\delta_e}^{a_z}$	A_{a_z}	-10.19	-23.7	-34.6	-38.6
	$1/T_{a_z1}$	0	0	0	0
	$1/T_{a_z2}$	-3.75	-5.95	-8.24	-8.63
	$1/T_{a_z3}$	-0.00182	-0.000026	0.0107	0.0531
	CG $1/T_{a_z4}$	4.83	7.29	9.59	100.9

TABLE XI-G

AILERON LATERAL TRANSFER FUNCTION FACTORS FOR THE DC-8

Note: Data are for body-fixed stability axes

		FLIGHT CONDITION			
		1	2	3	4
Mach No., (-)		0.218	0.443	0.84	0.88
Altitude, h (ft)		0	15,000	33,000	33,000
CG (% \bar{c})		15	15	15	15
Weight, W (lb)		190,000	190,000	230,000	230,000
Δ_{lat}	$1/T_s$	-0.013	0.00649	0.00404	0.00447
	$1/T_R$	1.121	1.329	1.254	1.356
	ζ_d	0.1096	0.1061	0.0793	0.0855
	ω_d	0.996	1.197	1.495	1.589
$N_{\delta_a}^p$	A_p	-0.726	-1.62	-2.11	-2.30
	$1/T_{p1}$	0	0	0	0
	ζ_p	0.223	0.1554	0.1072	0.1094
	ω_p	0.943	1.166	1.515	1.620
ϕ N_{δ_a}	A_ϕ	-0.726	-1.62	-2.11	-2.30
	ζ_ϕ	0.223	0.1554	0.1072	0.1094
	ω_ϕ	0.943	1.166	1.515	1.620
$N_{\delta_a}^r$	A_r	-0.0532	-0.01875	-0.0652	-0.0788
	$1/T_{r1}$	0.998	1.589	1.644	1.757
	ζ_r	-0.656	-0.727	-0.392	-0.345
	ω_r	1.242	2.23	1.323	1.269
$N_{\delta_a}^\beta$	A_β	0.0532	0.01875	0.0652	-0.0788
	$1/T_{\beta 1}$	-2.75	-7.9	-1.036	-0.704
	$1/T_{\beta 2}$	0.203	0.197	0.291	0.404
	$1/T_{\beta 3}$	—	—	—	—

TABLE XI-H

RUDDER LATERAL TRANSFER FUNCTION FACTORS FOR THE DC-8

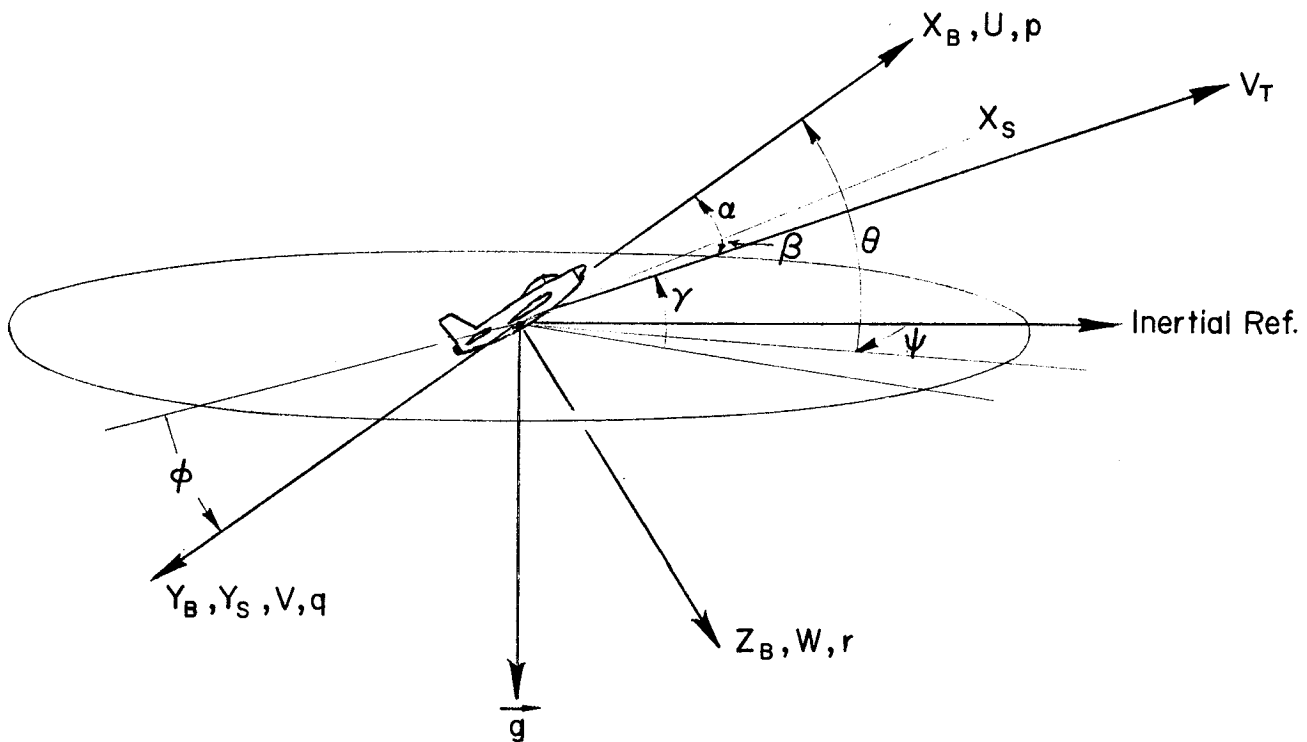
Note: Data are for body-fixed stability axes.

		FLIGHT CONDITION			
		1	2	3	4
Mach No., M (-)		0.218	0.443	0.84	0.88
Altitude, h (ft)		0	15,000	33,000	33,000
CG (% \bar{c})		15	15	15	15
Weight, W (lb)		190,000	190,000	230,000	230,000
Δ_{lat}	$1/T_s$	-0.013	0.00649	0.00404	0.00447
	$1/T_R$	1.121	1.329	1.254	1.356
	ζ_d	0.1096	0.1061	0.0793	0.0855
	ω_d	0.996	1.197	1.495	1.589
$N_{\delta r}^p$	A_p	0.1813	0.392	0.545	0.612
	$1/T_{p1}$	0	0	0	0
	$1/T_{p2}$	1.028	1.85	2.43	2.57
	$1/T_{p3}$	-2.13	-2.56	-3.01	-3.15
$N_{\delta r}^p$	A_ϕ	0.1813	0.392	0.545	0.612
	$1/T_{\phi 1}$	1.028	1.85	2.43	2.57
	$1/T_{\phi 2}$	-2.13	-2.56	-3.01	-3.15
$N_{\delta r}^r$	A_r	-0.389	-0.864	-1.165	-1.277
	$1/T_{r1}$	1.124	1.335	1.276	1.377
	ζ_r	-0.0743	-0.0451	-0.0619	-0.0475
	ω_r	0.339	0.330	0.323	0.323
$N_{\delta r}^\beta$	A_β	0.0238	0.0288	0.0222	0.0233
	$1/T_{\beta 1}$	-0.0559	-0.01475	-0.00726	-0.00637
	$1/T_{\beta 2}$	1.141	1.297	1.217	1.323
	$1/T_{\beta 3}$	16.47	30.2	52.6	55.0
$N_{\delta r}^{\delta y}$	A_{ay}	5.79	13.48	18.33	20.1
	$1/T_{ay1}$	-0.819	-0.0347	-0.01883	-0.01746
	$1/T_{ay2}$	-0.1077	1.535	1.122	1.231
	$1/T_{ay3}$ (ζ_{ay})	(0.994)	-1.157	-1.418	-1.494
CG	$1/T_{ay4}$ (ω_{ay})	(1.078)	1.147	1.723	1.819

APPENDIX A

AXIS SYSTEMS, SYMBOLS, AND DERIVATIVE DEFINITIONS

1. AXIS SYSTEMS



X_B, Y_B, Z_B - The Body-Axis System consists of right-handed, orthogonal axes whose origin is fixed at the nominal aircraft center of gravity. It's orientation remains fixed with respect to the aircraft, the X_B and Z_B axes being in the plane of symmetry. The exact alignment of X_B axis is arbitrary, herein it is taken along the body centerline reference.

X_S, Y_S, Z_S - The Stability-Axis System is that particular body-axis system for which the X_S -axis is coincident with the projection of the total steady-state velocity vector (V_{T_0}) on the aircraft's plane of symmetry. It's orientation remains fixed with respect to the aircraft.

2. SYMBOLS

a	Speed of sound in air	ft/sec
a_y	Lateral acceleration along the Y-Body Axis at the center of gravity (positive out right wing)	ft/sec ²
a_y'	Lateral acceleration parallel to the Y-Body Axis at a distance l_x and l_z from the c.g., $a_y' = a_y + l_x \dot{r} - l_z \dot{p}$	ft/sec ²
a_z	Normal acceleration along the Z-Body Axis at the c.g. (positive down)	ft/sec ²
a_z'	Normal acceleration parallel to the Z-Body Axis at a distance l_x from the c.g., $a_z' = a_z - l_x \dot{q}$	ft/sec ²
b	Reference wing span	ft
c	Reference chord	ft
CG	Center of gravity	
D	Aerodynamic force (drag) along the total velocity vector (positive aft)	lbs
g	Acceleration due to gravity	ft/sec ²
h	Altitude	ft
I_x, I_y, I_z	Moments of inertia referred to body axis	slug-ft ²
I_{xz}	Product of inertia referred to body axis	slug-ft ²
$j\omega$	The imaginary portion of the complex variable $s = \sigma \pm j\omega$	rad/sec
l_x	Distance along the X-Body Axis from the c.g. (positive forward)	ft
l_z	Distance along the Z-Body Axis from the c.g. (positive down)	ft
L	Rolling moment about the X-axis due to aerodynamic torques (positive right wing down)	ft-lb

L	Aerodynamic force (lift) perpendicular to the total velocity vector in the aircraft's plane of symmetry (positive up)	lbs
m	Mass	slugs
M	Mach number	
M	Pitching moment about the Y-axis due to aerodynamic torques (positive nose up)	ft-lb
MAC	Mean aerodynamic chord	ft
MGC	Mean geometric chord	ft
N	Aerodynamic normal force along the Z-Body Axis <u>but</u> positive up	lbs
N	Yawing moment about Z-axis due to aerodynamic torques (positive nose right)	ft-lbs
p	Roll rate, angular velocity about X-axis (positive right wing down)	rad/sec
q	Pitch rate, angular velocity about Y-axis (positive nose up)	rad/sec
\bar{q}	Dynamic pressure, $1/2 \rho V_{T_0}^2$	lbs/ft ²
r	Yaw rate, angular velocity about Z-axis (positive nose right)	rad/sec
r _{RG}	Yaw rate gyro signal	rad/sec
s	Laplace operator, $\sigma + j\omega$	rad/sec
S	Reference wing area	ft ²
T.E.	Trailing edge	
u	Linear perturbed velocity along the X-axis (positive forward)	ft/sec
U ₀	Linear steady-state velocity along the X-axis (positive forward)	ft/sec
v	Linear perturbed velocity along the Y-axis (positive out right wing)	ft/sec
V _{T₀}	Total linear steady-state velocity (positive forward)	ft/sec

w	Linear perturbed velocity along the Z-axis (positive down)	ft/sec
W	Weight	lbs
W ₀	Linear steady-state velocity along the Z-axis (positive down)	ft/sec
X	Aerodynamic force along the X-axis (positive forward)	lbs
Y	Aerodynamic force along Y-axis (positive out right wing)	lbs
z _j	Perpendicular distance from c.g. to thrust line (positive for nose up pitching moment due to thrust)	ft
Z	Aerodynamic force along Z-axis (positive down)	lbs
α	Perturbed angle of attack	rad
α_0	Steady-state (trim) angle of attack	deg
β	Sideslip angle	rad
γ_0	Steady-state flight path angle	deg
δ_a	Aileron control surface deflection, (includes spoiler effects, etc.), (positive for positive rolling moment)	rad
δ_e	Elevator surface deflection from trim, (positive for nose down pitching moment for aft surface)	rad
δ_{e_0}	Trim elevator deflection	deg
δ_r	Rudder deflection [positive for nose left yawing moment (negative N)]	rad
Δ	Denominator of airframe transfer function	
ζ_i	Damping ratio of linear second order mode particularized by the subscript	
θ	Pitch angle, $\int q dt$ for straight and level flight, positive nose up	rad

ξ_0	Inclination of thrust line with X-axis [positive gives negative (-) Z force]	deg
ρ	Mass density of air	slugs/ft ³
σ	The real portion of the complex variable $s = \sigma \pm j\omega$	rad/sec
φ	Roll angle, ($\cos \theta_0 \int p \, dt - \sin \theta_0 \int r \, dt$) in straight and level flight, (positive right wing down)	rad
ω_i	Undamped natural frequency of a second order mode, particularized by subscript	rad/sec

Special Subscript

a	Aileron
d	Dutch roll
e	Elevator
p	Phugoid
r	Rudder
R	Roll subsidence
s	Spiral
sp	Short period

3. NONDIMENSIONAL DERIVATIVE DEFINITIONS

a) Longitudinal Body Axis

$$C_N = \frac{N}{\bar{q} S}, \text{ positive up}$$

$$C_X = -\frac{X}{\bar{q} S}, \text{ positive aft}$$

$$C_{N\alpha} = \partial C_N / \partial \alpha$$

$$C_{N\dot{\alpha}} = \frac{2V_{T_0}}{c} \partial C_N / \partial \dot{\alpha}$$

$$C_{NM} = \partial C_N / \partial M$$

$$C_{N\delta} = \partial C_N / \partial \delta$$

$$C_{X\alpha} = \partial C_X / \partial \alpha$$

$$C_{XM} = \partial C_X / \partial M$$

$$C_{X\delta} = \partial C_X / \partial \delta$$

$$C_M = \frac{M}{\bar{q} S c}$$

$$C_{M\alpha} = \partial C_M / \partial \alpha$$

$$C_{M\dot{\alpha}} = \frac{2V_{T_0}}{c} \partial C_M / \partial \dot{\alpha}$$

$$C_{MM} = \partial C_M / \partial M$$

$$C_{Mq} = \frac{2V_{T_0}}{c} \partial C_M / \partial q$$

b) Longitudinal Stability Axis

$$C_L = \frac{L}{\bar{q} S}, \text{ positive up}$$

$$C_D = \frac{D}{\bar{q} S}, \text{ positive aft}$$

$$C_{L\alpha} = \partial C_L / \partial \alpha$$

$$C_{L\dot{\alpha}} = \frac{2V_{T_0}}{c} \partial C_L / \partial \dot{\alpha}$$

$$C_{LM} = \partial C_L / \partial M$$

$$C_{L\delta} = \partial C_L / \partial \delta$$

$$C_{D\alpha} = \partial C_D / \partial \alpha$$

$$C_{DM} = \partial C_D / \partial M$$

$$C_{D\delta} = \partial C_D / \partial \delta$$

Pitching moment

derivatives are

identical to

those for body axis

c) Lateral Body and Stability Axis

Though physically and numerically different,* see Appendix B, the same symbols are used for body axis and stability axis lateral rolling and yawing moment derivatives. The sideforce derivatives (C_y , etc.) are physically and numerically the same in both axis systems. When the rolling or yawing moment derivatives are given in this report the axis system is specified. When using the following all quantities should be for the same axis system.

$$\begin{array}{lll} C_y = \frac{Y}{\bar{q}S} & C_l = \frac{L}{\bar{q}Sb} & C_n = \frac{N}{\bar{q}Sb} \\ C_{y\beta} = \frac{\partial C_y}{\partial \beta} & C_{l\beta} = \frac{\partial C_l}{\partial \beta} & C_{n\beta} = \frac{\partial C_n}{\partial \beta} \\ C_{y\delta} = \frac{\partial C_y}{\partial \delta} & C_{lp} = \frac{2V_{T_0}}{b} \frac{\partial C_l}{\partial p} & C_{np} = \frac{2V_{T_0}}{b} \frac{\partial C_n}{\partial p} \\ & C_{lr} = \frac{2V_{T_0}}{b} \frac{\partial C_l}{\partial r} & C_{nr} = \frac{2V_{T_0}}{b} \frac{\partial C_n}{\partial r} \\ & C_{l\delta} = \frac{\partial C_l}{\partial \delta} & C_{n\delta} = \frac{\partial C_n}{\partial \delta} \end{array}$$

*The exception is the zero trim angle of attack condition.

4. DIMENSIONAL STABILITY DERIVATIVE DEFINITIONS

The same symbols are used for body- and stability-axis dimensional derivatives. Care should be exercised so that a consistent set of quantities are used.

a) Longitudinal Body Axis

$$X_u^* = X_u + T_u \cos \xi_0 \quad 1/\text{sec}$$

$$X_u = \frac{\rho S U_0}{m} \left(-\frac{M}{2} C_{X_M} - C_X + \frac{W_0}{2U_0} C_{X\alpha} \right) \quad 1/\text{sec}$$

$$X_w = \frac{\rho S U_0}{2m} \left[-C_{X\alpha} - 2 \frac{W_0}{U_0} \left(C_X + \frac{M}{2} C_{X_M} \right) \right] \quad 1/\text{sec}$$

$$X_{\delta e} = -\frac{\rho S V_{T_0}^2}{2m} C_{X\delta e} \quad \frac{\text{ft}}{\text{sec}^2 \text{rad}}$$

$$Z_u^* = Z_u - T_u \sin \xi_0 \quad 1/\text{sec}$$

$$Z_u = \frac{\rho S U_0}{m} \left(-\frac{M}{2} C_{N_M} - C_N + \frac{W_0}{2U_0} C_{N\alpha} \right) \quad 1/\text{sec}$$

$$Z_w = \frac{\rho S U_0}{2m} \left[-C_{N\alpha} - 2 \frac{W_0}{U_0} \left(C_N + \frac{M}{2} C_{N_M} \right) \right] \quad 1/\text{sec}$$

$$Z_{\dot{w}} = -\frac{\rho S e}{4m} \frac{U_0}{V_{T_0}} C_{N\dot{\alpha}}$$

$$Z_{\delta e} = -\frac{\rho S V_{T_0}^2}{2m} C_{N\delta e} \quad \frac{\text{ft}}{\text{sec}^2 \text{rad}}$$

$$M_u^* = M_u + \frac{Z_{j_m}}{I_y} T_u \quad \frac{1}{\text{sec-ft}}$$

$$\begin{aligned}
M_u &= \frac{\rho S c U_o}{2 I_y} \left[\frac{M}{2} C_{mM} + C_m - \frac{W_o}{2 U_o} C_{m\alpha} \right] && \frac{1}{\text{sec-ft}} \\
M_w &= \frac{\rho S c U_o}{2 I_y} \left[C_{m\alpha} + \frac{2 W_o}{U_o} \left(C_m + \frac{M}{2} C_{mM} \right) \right] && \frac{1}{\text{sec-ft}} \\
M_{\dot{w}} &= \frac{\rho S c^2}{4 I_y} \frac{U_o}{V_{T_o}} C_{m\dot{\alpha}} && \frac{1}{\text{sec-ft}} \\
M_{\alpha} &= U_o M_w && 1/\text{sec}^2 \\
M_{\dot{\alpha}} &= U_o M_{\dot{w}} && 1/\text{sec} \\
M_q &= \frac{\rho S c^2 V_{T_o}}{4 I_y} C_{mq} && 1/\text{sec} \\
M_{\delta_e} &= \frac{\rho S c V_{T_o}^2}{2 I_y} C_{m\delta_e} && 1/\text{sec}^2 \\
T_u &= \frac{1}{a m} \partial T / \partial M && 1/\text{sec}
\end{aligned}$$

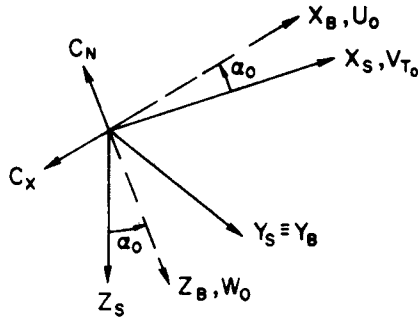
b) Lateral Body Axis

$$\begin{aligned}
Y_v &= (\rho S V_{T_o} / 2 m) C_{y\beta} && 1/\text{sec} \\
Y_{\beta} &= V_{T_o} Y_v && \text{ft}/\text{sec}^2 \\
Y_{\delta_a} &= (\rho S V_{T_o}^2 / 2 m) C_{y\delta_a} && \text{ft}/\text{sec}^2 \\
Y_{\delta_r} &= (\rho S V_{T_o}^2 / 2 m) C_{y\delta_r} && \text{ft}/\text{sec}^2 \\
Y_{\delta_r}^* &= (\rho S V_{T_o} / 2 m) C_{y\delta_r} && 1/\text{sec} \\
L_{\beta} &= (\rho S V_{T_o}^2 b / 2 I_x) C_{l_{\beta}} && 1/\text{sec}^2 \\
L_p &= (\rho S V_{T_o} b^2 / 4 I_x) C_{l_p} && 1/\text{sec} \\
L_r &= (\rho S V_{T_o} b^2 / 4 I_x) C_{l_r} && 1/\text{sec}
\end{aligned}$$

$$\begin{aligned}
L_{\delta_a} &= (\rho S V_{T_0}^2 b / 2 I_x) C_{l_{\delta_a}} && 1/\text{sec}^2 \\
L_{\delta_r} &= (\rho S V_{T_0}^2 b / 2 I_x) C_{l_{\delta_r}} && 1/\text{sec}^2 \\
Y_{\delta_a}^* &= (\rho S V_{T_0} / 2 m) C_{y_{\delta_a}} && 1/\text{sec} \\
N_{\beta} &= (\rho S V_{T_0}^2 b / 2 I_z) C_{n_{\beta}} && 1/\text{sec}^2 \\
N_p &= (\rho S V_{T_0} b^2 / 4 I_z) C_{n_p} && 1/\text{sec} \\
N_r &= (\rho S V_{T_0} b^2 / 4 I_z) C_{n_r} && 1/\text{sec} \\
N_{\delta_a} &= (\rho S V_{T_0}^2 b / 2 I_z) C_{n_{\delta_a}} && 1/\text{sec}^2 \\
N_{\delta_r} &= (\rho S V_{T_0}^2 b / 2 I_z) C_{n_{\delta_r}} && 1/\text{sec}^2 \\
L_{\beta} &= (L_{\beta} + I_{xz} N_{\beta} / I_x) G && 1/\text{sec}^2 \\
L_p' &= (L_p + I_{xz} N_p / I_x) G && 1/\text{sec} \\
L_r' &= (L_r + I_{xz} N_r / I_x) G && 1/\text{sec} \\
L_{\delta_r}' &= (L_{\delta_r} + I_{xz} N_{\delta_r} / I_x) G && 1/\text{sec}^2 \\
L_{\delta_a}' &= (L_{\delta_a} + I_{xz} N_{\delta_a} / I_x) G && 1/\text{sec}^2 \\
N_{\beta}' &= (N_{\beta} + I_{xz} L_{\beta} / I_z) G && 1/\text{sec}^2 \\
N_p' &= (N_p + I_{xz} L_p / I_z) G && 1/\text{sec} \\
N_r' &= (N_r + I_{xz} L_r / I_z) G && 1/\text{sec} \\
N_{\delta_r}' &= (N_{\delta_r} + I_{xz} L_{\delta_r} / I_z) G && 1/\text{sec}^2 \\
N_{\delta_a}' &= (N_{\delta_a} + I_{xz} L_{\delta_a} / I_z) G && 1/\text{sec}^2 \\
G &= \frac{1}{1 - \frac{I_{xz}^2}{I_x I_z}}
\end{aligned}$$

APPENDIX B

TRANSFORMATION OF NON-DIMENSIONAL STABILITY AXIS DERIVATIVES TO BODY AXIS



$$U_0 = V_{T_0} \cos \alpha_0$$

$$W_0 = V_{T_0} \sin \alpha_0$$

LONGITUDINAL

Body Axis

$$C_N = C_L \cos \alpha_0 + C_D \sin \alpha_0$$

$$C_X = C_D \cos \alpha_0 - C_L \sin \alpha_0$$

$$C_{N\alpha} = C_{L\alpha} \cos \alpha_0 - C_L \sin \alpha_0 + C_{D\alpha} \sin \alpha_0 + C_D \cos \alpha_0$$

$$C_{N\dot{\alpha}} = C_{L\dot{\alpha}} \cos \alpha_0$$

$$C_{NM} = C_{LM} \cos \alpha_0 + C_{DM} \sin \alpha_0$$

$$C_{N\delta} = C_{L\delta} \cos \alpha_0 + C_{D\delta} \sin \alpha_0$$

$$C_{X\alpha} = C_{D\alpha} \cos \alpha_0 - C_D \sin \alpha_0 - C_{L\alpha} \sin \alpha_0 - C_L \cos \alpha_0$$

$$C_{XM} = C_{DM} \cos \alpha_0 - C_{LM} \sin \alpha_0$$

$$C_{X\delta} = C_{D\delta} \cos \alpha_0 - C_{L\delta} \sin \alpha_0$$

$$C_m, C_{m\alpha}, C_{m\dot{\alpha}}, C_{m\alpha}, C_{mM}, C_{m\delta} - \text{UNCHANGED}$$

LATERAL

Body Axis

$$(C_{l\beta})_B = C_{l\beta} \cos \alpha_0 - C_{n\beta} \sin \alpha_0$$

$$(C_{l_p})_B = C_{l_p} \cos^2 \alpha_0 - (C_{l_r} + C_{n_p}) \sin \alpha_0 \cos \alpha_0 + C_{n_r} \sin^2 \alpha_0$$

$$(C_{l_r})_B = C_{l_r} \cos^2 \alpha_0 - (C_{n_r} - C_{l_p}) \sin \alpha_0 \cos \alpha_0 - C_{n_p} \sin^2 \alpha_0$$

$$(C_{l\delta})_B = C_{l\delta} \cos \alpha_0 - C_{n\delta} \sin \alpha_0$$

$$(C_{n\beta})_B = C_{n\beta} \cos \alpha_0 + C_{l\beta} \sin \alpha_0$$

$$(C_{n_p})_B = C_{n_p} \cos^2 \alpha_0 - (C_{n_r} - C_{l_p}) \sin \alpha_0 \cos \alpha_0 - C_{l_r} \sin^2 \alpha_0$$

$$(C_{n_r})_B = C_{n_r} \cos^2 \alpha_0 + (C_{l_r} + C_{n_p}) \sin \alpha_0 \cos \alpha_0 + C_{l_p} \sin^2 \alpha_0$$

$$(C_{n\delta})_B = C_{n\delta} \cos \alpha_0 + C_{l\delta} \sin \alpha_0$$

$$C_{y\beta}, C_{y\delta_r}, C_{y\delta_a} - \text{UNCHANGED}$$

APPENDIX C

EQUATIONS OF MOTION, TRANSFER FUNCTIONS, AND COUPLING NUMERATORS

1. Longitudinal

a. Equations

$$\begin{bmatrix} s - X_u^* & -X_w & W_0 s + g \cos \theta_0 \\ -Z_u^* & (1 - Z_w^*)s - Z_w & -U_0 s + g \sin \theta_0 \\ -M_u^* & -(M_w^* s + M_w) & s^2 - M_q s \end{bmatrix} \begin{bmatrix} u \\ w \\ \theta \end{bmatrix} = \begin{bmatrix} X_{\delta_e} \\ Z_{\delta_e} \\ M_{\delta_e} \end{bmatrix} \begin{bmatrix} \delta_e \end{bmatrix}$$

$$q = s\theta$$

$$\dot{h} = -w \cos \theta_0 + u \sin \theta_0 + (U_0 \cos \theta_0 + W_0 \sin \theta_0)\theta$$

$$a_z = sw - U_0 q + (g \sin \theta_0)\theta$$

$$a_z' = a_z - l_x s^2 \theta$$

b. Transfer Functions

$$\frac{\theta}{\delta_e} = \frac{N_{\delta_e}^{\theta}}{\Delta}$$

1) Denominator, $\Delta = As^4 + Bs^3 + Cs^2 + Ds + E$

$$A = (1 - Z_w^*)$$

$$B = -(M_q + X_u^*)(1 - Z_w^*) - Z_w - M_{\alpha}$$

$$C = M_q Z_w - M_{\alpha} + X_u^* [(M_q)(1 - Z_w^*) + Z_w + M_{\alpha}]$$

$$- X_w Z_u^* + W_0 [M_w Z_u^* + M_u^* (1 - Z_w^*)] + g M_w \sin \theta_0$$

$$D = -X_u^*(M_q Z_w - M_\alpha) - M_u^* X_\alpha + M_q X_w Z_u^* + g \left[\frac{M_w Z_u^*}{w} + \frac{M_u^* (1 - Z_w)}{u} \right] \cos \theta_0 + W_0 (M_w Z_u^* - M_u^* Z_w) + g (M_w - \frac{M_u^* X_w}{w}) \sin \theta_0$$

$$E = g (M_w Z_u^* - M_u^* Z_w) \cos \theta_0 + g (M_u^* X_w - M_w X_u^*) \sin \theta_0$$

2) δ Numerators

$$N_\delta^\theta = A_\theta s^2 + B_\theta s + C_\theta$$

$$A_\theta = Z_\delta M_w + M_\delta (1 - Z_w)$$

$$B_\theta = X_\delta \left[\frac{M_w Z_u^*}{w} + \frac{M_u^* (1 - Z_w)}{u} \right] + Z_\delta (M_w - \frac{M_u^* X_w}{w}) - M_\delta [Z_w + \frac{X_u^* (1 - Z_w)}{u}]$$

$$C_\theta = X_\delta (M_w Z_u^* - M_u^* Z_w) + Z_\delta (M_u^* X_w - M_w X_u^*) + M_\delta (Z_w X_u^* - X_w Z_u^*)$$

$$N_\delta^u = A_u s^3 + B_u s^2 + C_u s + D_u$$

$$A_u = X_\delta (1 - Z_w)$$

$$B_u = -X_\delta [M_q (1 - Z_w) + Z_w + M_\alpha] + Z_\delta X_w - W_0 [Z_\delta M_w + M_\delta (1 - Z_w)]$$

$$C_u = X_\delta (M_q Z_w - M_\alpha) - Z_\delta (g M_w \cos \theta_0 + M_q X_w) + M_\delta [X_\alpha - (g \cos \theta_0) (1 - Z_w)] + W_0 (Z_w M_\delta - M_w Z_\delta) + g X_\delta M_w \sin \theta_0$$

$$D_u = g (Z_w M_\delta - M_w Z_\delta) \cos \theta_0 + g (X_\delta M_w - M_\delta X_w) \sin \theta_0$$

$$N_\delta^w = A_w s^3 + B_w s^2 + C_w s + D_w$$

$$A_w = Z_\delta$$

$$B_w = -Z_\delta (M_q + X_u^*) + U_0 M_\delta + X_\delta Z_u^*$$

$$C_w = X_u^* (Z_\delta M_q - U_0 M_\delta) + W_0 (Z_\delta M_u^* - M_\delta Z_u^*) - g M_\delta \sin \theta_0 + X_\delta (M_u^* U_0 - Z_u^* M_q)$$

$$D_w = g (Z_\delta M_u^* - M_\delta Z_u^*) \cos \theta_0 + g M_\delta X_u^* \sin \theta_0 - X_\delta M_u^* g \sin \theta_0$$

$$N_{\delta}^h = A_h^{\cdot} s^3 + B_h^{\cdot} s^2 + C_h^{\cdot} s + D_h^{\cdot}$$

$$A_h^{\cdot} = -\cos \theta_0 A_w + \sin \theta_0 A_u$$

$$B_h^{\cdot} = -\cos \theta_0 B_w + \sin \theta_0 B_u + (U_0 \cos \theta_0 + W_0 \sin \theta_0) A_{\theta}$$

$$C_h^{\cdot} = -\cos \theta_0 C_w + \sin \theta_0 C_u + (U_0 \cos \theta_0 + W_0 \sin \theta_0) B_{\theta}$$

$$D_h^{\cdot} = -\cos \theta_0 D_w + \sin \theta_0 D_u + (U_0 \cos \theta_0 + W_0 \sin \theta_0) C_{\theta}$$

$$N_{\delta}^{a_z} = A_{a_z}^{\cdot} s^4 + B_{a_z}^{\cdot} s^3 + C_{a_z}^{\cdot} s^2 + D_{a_z}^{\cdot} s + E_{a_z}^{\cdot}$$

$$A_{a_z}^{\cdot} = A_w - l_x A_{\theta}$$

$$B_{a_z}^{\cdot} = B_w - l_x B_{\theta} - U_0 A_{\theta}$$

$$C_{a_z}^{\cdot} = C_w - l_x C_{\theta} - U_0 B_{\theta} + g \sin \theta_0 A_{\theta}$$

$$D_{a_z}^{\cdot} = D_w - U_0 C_{\theta} + g \sin \theta_0 B_{\theta}$$

$$E_{a_z}^{\cdot} = + g \sin \theta_0 C_{\theta}$$

To obtain a_z , let $l_x = 0$.

2. Lateral

a. Equations

$$\begin{bmatrix} s - Y_v & -\frac{W_0 s + g \cos \theta_0}{V_{T_0}} & \frac{U_0 s - g \sin \theta_0}{V_{T_0} s} \\ -I_p^{\cdot} & s(s - L_p^{\cdot}) & -L_r^{\cdot} \\ -N_p^{\cdot} & -N_p^{\cdot} s & s - N_r^{\cdot} \end{bmatrix} \begin{bmatrix} \beta \\ \frac{p}{s} \\ r \end{bmatrix} = \begin{bmatrix} Y_{\delta_a}^* & Y_{\delta_r}^* \\ L_{\delta_a}^{\cdot} & L_{\delta_r}^{\cdot} \\ N_{\delta_a}^{\cdot} & N_{\delta_r}^{\cdot} \end{bmatrix} \begin{bmatrix} \delta_a \\ \delta_r \end{bmatrix}$$

$$v = V_{T_0} \beta$$

$$a_y = sv + U_0 r - W_0 p - g(\cos \theta_0) \varphi$$

$$\varphi = \frac{p}{s} + \frac{r}{s} \tan \theta_0$$

$$a_y^{\cdot} = a_y + l_{xlat} sr - l_{zsp}$$

$$\psi = \frac{1}{\cos \theta_0} \frac{r}{s}$$

b. Transfer Functions

$$\frac{p}{\delta_a} = \frac{N_{\delta_a}^{\phi}}{\Delta_{lat}} \quad ; \quad \frac{r}{\delta_r} = \frac{N_{\delta_r}^r}{\Delta_{lat}} \quad ; \quad \text{etc.}$$

1) Denominator, $\Delta_{lat} = as^4 + bs^3 + cs^2 + ds + e$

a = 1

b = $-(Y_v + L_p^i + N_r^i)$

c = $\frac{U_o}{V_{T_o}} N_{\beta}^i + L_p^i(Y_v + N_r^i) - N_p^i L_r^i + Y_v N_r^i - \frac{W_o L_{\beta}^i}{V_{T_o}}$

d = $\frac{U_o}{V_{T_o}} (N_p^i L_{\beta}^i - L_p^i N_{\beta}^i) + Y_v(N_p^i L_r^i - L_p^i N_r^i) - \frac{g}{V_{T_o}} (L_{\beta}^i \cos \theta_o + N_{\beta}^i \sin \theta_o)$
 $+ \frac{W_o}{V_{T_o}} (L_p^i N_r^i - N_{\beta}^i L_r^i)$

e = $\frac{g}{V_{T_o}} [(L_{\beta}^i N_r^i - N_{\beta}^i L_r^i) \cos \theta_o - (N_p^i L_{\beta}^i - L_p^i N_{\beta}^i) \sin \theta_o]$

2) δ (δ_a or δ_r) Numerators

$N_{\delta}^{\beta} = A_{\beta} s^3 + B_{\beta} s^2 + C_{\beta} s + D_{\beta}$
$A_{\beta} = Y_{\delta}^*$
$B_{\beta} = -Y_{\delta}^* [L_p^i + N_r^i] - N_{\delta}^i \frac{U_o}{V_{T_o}} + \frac{W_o}{V_{T_o}} L_{\delta}^i$
$C_{\beta} = Y_{\delta}^* (L_p^i N_r^i - N_p^i L_r^i) + L_{\delta}^i \frac{g}{V_{T_o}} \cos \theta_o + (N_{\delta}^i L_p^i - L_{\delta}^i N_p^i) \frac{U_o}{V_{T_o}}$ $+ \frac{W_o}{V_{T_o}} (N_{\delta}^i L_r^i - L_{\delta}^i N_r^i) + N_{\delta}^i \frac{g}{V_{T_o}} \sin \theta_o$
$D_{\beta} = \frac{g}{V_{T_o}} (N_{\delta}^i L_r^i - L_{\delta}^i N_r^i) \cos \theta_o + \frac{g}{V_{T_o}} (N_p^i L_{\delta}^i - N_{\delta}^i L_p^i) \sin \theta_o$

$$N_{\delta}^p = A_p s^3 + B_p s^2 + C_p s + D_p$$

$$A_p = L_{\delta}'$$

$$B_p = Y_{\delta}' L_{\beta}' - L_{\delta}' (N_r' + Y_v) + N_{\delta}' L_r'$$

$$C_p = Y_{\delta}' (L_r' N_{\beta}' - L_{\beta}' N_r') + L_{\delta}' Y_v N_r' - N_{\delta}' Y_v L_r' + (L_{\delta}' N_{\beta}' - N_{\delta}' L_{\beta}') \frac{U_0}{V_{T_0}}$$

$$D_p = -\frac{g}{V_{T_0}} (L_{\delta}' N_{\beta}' - N_{\delta}' L_{\beta}') \sin \theta_0$$

$$N_{\delta}^r = A_r s^3 + B_r s^2 + C_r s + D_r$$

$$A_r = N_{\delta}'$$

$$B_r = Y_{\delta}' N_{\beta}' + L_{\delta}' N_p' - N_{\delta}' (Y_v + L_p')$$

$$C_r = Y_{\delta}' (L_{\beta}' N_p' - N_{\beta}' L_p') - L_{\delta}' Y_v N_p' + N_{\delta}' Y_v L_p' + \frac{W_0}{V_{T_0}} (L_{\delta}' N_{\beta}' - N_{\delta}' L_{\beta}')$$

$$D_r = \frac{g}{V_{T_0}} (L_{\delta}' N_{\beta}' - N_{\delta}' L_{\beta}') \cos \theta_0$$

$$N_{\delta}^{\phi} = A_{\phi} s^2 + B_{\phi} s + C$$

$$A_{\phi} = A_p + A_r \tan \theta_0$$

$$B_{\phi} = B_p + B_r \tan \theta_0$$

$$C_{\phi} = C_p + C_r \tan \theta_0$$

$$N_{\delta}^{a_y'} = A_{a_y}' s^4 + B_{a_y}' s^3 + C_{a_y}' s^2 + D_{a_y}' s + E_{a_y}'$$

$$A_{a_y}' = V_{T_O} A_{\beta} + l_{x_{lat}} A_r - l_z A_p$$

$$B_{a_y}' = V_{T_O} B_{\beta} + U_o A_r - W_o A_p + l_{x_{lat}} B_r - l_z B_p$$

$$C_{a_y}' = V_{T_O} C_{\beta} + U_o B_r - W_o B_p - g \cos \theta_o A_{\phi} + l_{x_{lat}} C_r - l_z C_p$$

$$D_{a_y}' = V_{T_O} D_{\beta} + U_o C_r - W_o C_p - g \cos \theta_o B_{\phi} + l_{x_{lat}} D_r - l_z D_p$$

$$E_{a_y}' = U_o D_r - W_o D_p - g \cos \theta_o C_{\phi}$$

To obtain a_y , let $l_{x_{lat}} = l_z = 0$.